



**Practical Design Guide
for
Glassfibre Reinforced Concrete (GRC).
(Using Limit State Theory)**

**The International
Glassfibre Reinforced Concrete
Association (GRCA)**

Version 1.1 March 2018

The International Glassfibre Reinforced Concrete Association (GRCA) has relationships with other associations connected with the GRC industry. Further information, together with a full list of GRCA Members, can be found on The International Glassfibre Reinforced Concrete Association (GRCA) website: www.grca.org.uk.

Membership of the GRCA is open to:

- Companies who manufacture or develop GRC products,
- Plant or material suppliers to the industry
- Professional partnerships or consultants
- Other interested parties.

Associate Membership is open to individuals with an interest in GRC who are not engaged in manufacture, other than at development or small company level.

Practical Design Guide for Glassfibre Reinforced Concrete (GRC).

Published by: The International Glassfibre Reinforced Concrete Association (GRCA)

Prepared by: The GRCA Technical Working Group, Chaired by Mr Glyn Jones

First published: March 2010

This edition published: March 2018

ISBN 0 946691 78 9

© The International Glassfibre Reinforced Concrete Association (GRCA)

The International Glassfibre Reinforced Concrete Association

PO Box 1454,
NORTHAMPTON
NN2 1DZ
United Kingdom

Tel: +44 (0) 330 111 GRCA
+44 (0) 330 111 4 7 2 2

Web: www.grca.org.uk

Email: info@grca.org.uk

Any recommendations contained herein are intended only as a general guide and, before being used in connection with any report or specification, they should be reviewed with regard to the full circumstances of such use. Although The International Glassfibre Reinforced Concrete Association (GRCA) ensures every care has been taken in the preparation of this document, no liability for negligence or otherwise can be accepted by The International Glassfibre Reinforced Concrete Association (GRCA), or the members of its working parties, its servants or agents.

All rights reserved. No part of this publication may be reproduced, stored in a retrieval system or transmitted in any form or by any means, electronic, mechanical, photocopying, recording or otherwise without the prior permission in writing of The International Glassfibre Reinforced Concrete Association (GRCA).

CONTENTS

1.	Introduction	6
1.1	Scope	6
1.2	Terms and Definitions	7
1.3	Types of GRC	11
1.4	Selection of Production Method & Raw Materials	14 - 21
	1.4.1 AR Glass Fibres	14
	1.4.2 Cement	16
	1.4.3 Sand	16
	1.4.4 Sand/Aggregate Facing Mixes	17
	1.4.5 Admixtures	17
	1.4.6 Polymers	18
	1.4.7 Water	18
	1.4.8 Pozzolans	18
	1.4.9 Pigments	18
	1.4.10 Paints, Sealers and Adhesives	19
1.5	Applications and Uses	20 - 21
2.	Physical Properties of GRC	22 - 31
2.1	Effects of Mix Composition and Fibre Content	22
2.2	Flexural Strengths	22
2.3	Tensile Strengths	23
2.4	Shear Strengths	24
2.5	Shrinkage and Creep	24
2.6	Impact Resistance	25
2.7	Density Water Absorption & Permeability	26
2.8	Fire Resistance	27
2.9	Sound Insulation	28
2.10	Thermal Insulation	29
2.11	Resistance to Carbonation	29
2.12	Thermal Expansion	30
2.13	Summary of Mechanical Properties	30
2.14	Time Dependent Properties	31
3.	Types of Panel Construction	32 - 39
3.1	Single Skin Construction	32
	3.1.1 Simple, Single Skin Panels	32
	3.1.2 Ribbed, Single Skin Panels	33
3.2	Stud Frame Construction	34
3.3	Sandwich Panel Construction	38
4.	Fixing Systems	40 - 43
4.1	Fixing Constraints	40
4.2	Encapsulated Fixings	40
4.3	Bonded Fixings	41
4.4	Face Fixings	41
4.5	Hidden Fixings	42
4.6	Secondary Fixings	42
4.7	Materials for Fixings	43

5.	Limit State Design of GRC Elements	44 - 53
5.1	Principles of Design	44
5.2	Partial Factors of Safety	45
5.3	Ultimate Limit State of Collapse	46
5.4	Serviceability Limit State	48
5.5	Shrinkage & Thermal Stresses	48
5.6	Bending & Shear	49 - 52
5.7	Direct Tension	53
5.8	Design Aids	54
	5.8.1 SectRib	53
	5.8.2 SectProp	58
5.9	Future Developments	59
6.	Limit State Design of Fixings	60
6.1	Functions of Fixings	60
6.2	Overview of Design Principles	60
6.3	Types of Fixings	61
6.4	Ultimate Limit State	63
6.5	Serviceability Limit State	63
6.6	Gravity Anchors in Stud Frame Construction	64
6.7	Seismic Effects	65
7.	Worked Examples	66 - 96

Included on CD

Specification for GRC

Section Properties Software (Shareware)

Rib Design Software (Shareware)

NOMENCLATURE

σ	<i>root mean square</i>
\bar{x}	<i>sample mean</i>
F_d	<i>ultimate design load</i>
F_k	<i>ultimate characteristic load</i>
γ_k	<i>ultimate partial factor of safety</i>
f_d	<i>ultimate design strength</i>
f_k	<i>ultimate characteristic strength</i>
γ_f	<i>ultimate partial load factor</i>
γ_{tv}	<i>ultimate partial factor to account for variations in thickness of GRC</i>
γ_b	<i>ultimate partial factor to account for differences in bending between test coupons and full size sections</i>
γ_c	<i>ultimate partial factor to account for mode of collapse and consequences of failure</i>
F_{sk}	<i>serviceability characteristic load</i>
F_{sd}	<i>serviceability design load</i>
γ_m	<i>serviceability global factor of safety</i>
γ_{ss}	<i>shrinkage stress</i>
γ_{ts}	<i>thermal stress</i>

1.1 Scope

This Practical Design Guide has been prepared by the Technical Committee of the Glassfibre Reinforced Concrete Association (GRCA) . The purpose of this publication is to provide a useful reference for specifiers, designers, manufacturers and fixers of glassfibre reinforced concrete (GRC) products and to encourage the use of good design practices. It complements the other technical publications of the GRCA, namely:

- Guide to Fixings for GRC Cladding
- Specification for the Manufacture, Curing and Testing of GRC products
- Methods of Testing GRC Material

National and international standards relating to the testing of GRC and its constituent materials are also available and further standards will become available in the future. GRC is used extensively worldwide, both as a functional and decorative construction material in building and civil engineering. This Guide discusses the relevance of good design practice for typical products.

GRC is a composite material comprising a mixture of hydraulic cement, silica sand, alkali resistant (AR) glass fibres and water. The glass fibres effectively reinforce the mortar mix thereby improving its tensile and flexural characteristics. GRC is a particularly attractive and durable cladding material. It can be moulded into a wide variety of complex shapes and profiles and is ideally suited to the popular fast-track approach of using lightweight, prefabricated cladding panels for the exteriors of modern buildings. The main advantage of GRC panels over the corresponding precast concrete alternatives is the considerable saving in weight. This results in significant savings in the costs of transportation, handling and erection of the panels. If this weight advantage is considered at the design stage, it should be possible to effect substantial economies in the design of foundations and superstructures for high rise building constructions. Other notable advantages of GRC cladding are its durability, chemical resistance, non-combustibility and good sound/heat insulation properties.

GRC is used extensively in the architectural and civil engineering fields with the main products being:

- cladding
- permanent formwork
- slates/roof features
- cornices
- coping units
- canopies
- porticos
- walkway roofs/walls
- sunscreens
- artificial rocks
- drainage channels
- street furniture
- planters
- arches
- balustrading
- box beams
- cable trays
- conservatory walling
- domed roofs
- door surrounds
- gutter units
- sound barriers
- string course features.

The design elements of this publication are based on limit state theory whereby the GRC product is designed to satisfy the limit states of collapse and serviceability using appropriate partial factors of safety. Several worked examples are included to demonstrate the use of these partial factors of safety.

1.2 Terms and Definitions

Admixture - A material added to modify the properties of mortar or cement slurry.

Air Permeability - The rate of flow of air through a material.

Alkali Resistant (AR) Glass Fibre - Fibre made from glass having a high zirconia (minimum of 16%) content formulated to improve resistance to attack by aqueous alkaline solutions.

Ambient Temperature - The temperature of the air surrounding an object.

Anchor - Devices for the attachment of the GRC skin to the stud framing system; this includes gravity, flex and seismic anchors.

Artificial Ageing - A condition to which test specimens are subjected to to simulate their exposure to natural weathering (using accelerated testing).

Backing Coat - The layer of GRC comprising fibre and cementitious slurry, the thickness of this layer must be equal or greater than the design thickness.

Bag and Bucket Tests - Very important methods for calibrating GRC spray equipment.

Bonding Pad - An additional covering of "GRC" material to secure anchors to the main element of "GRC" (typically cladding panels).

BOP - Bend over point (tensile), namely, the stress at which the stress/strain curve deviates from a straight line variation when a sample of GRC is tested in direct tension.

Carbonation - The reaction between carbon dioxide and a hydroxide or oxide to form a carbonate, especially in cement paste or mortar; the reaction with calcium hydroxide to produce calcium carbonate. GRC offers an extremely high resistance to carbonation.

Characteristic Property - The value of a property above which 95% of the population of all possible measurements of that property are expected to lie.

Chopped Glass - Non-continuous multi-filament glass fibre strands; resulting from chopping the roving in a spray process.

Cladding Panel - A lightweight non-structural GRC prefabricated building component produced by a spray technique to form an exterior or interior wall/column panel.

Compaction - The process whereby the volume of the face mix or GRC backing is reduced to a minimum practical volume by the reduction of voids usually by vibrating, tamping, rolling or some combination of these.

Composite - A material formed by combining two or more materials; but so interconnected that the combined components act together as a single entity, eg GRC

Coupon - Specimen for testing.

Creep - The time dependant change in dimension or shape caused by a sustained load.

Curing - The process by which moisture is retained in the GRC product to allow full hydration.

Dry Curing - A method of curing carried out by the addition of the appropriate quantity of acrylic polymer to the GRC mix.

Dry density - The weight per unit volume of an oven dry specimen.

E-Glass Fibre - Borosilicate fibres widely used for the reinforcement of plastics, but not recommended for use with portland cement.

Efflorescence - A deposit of salts, usually white, formed on the surface of the skin. It is a substance that has emerged in solution from within the GRC backing or face mix and deposited by evaporation.

Engineer - The person or authority responsible for the design of the GRC product.

Facing Coat - An initial layer without fibre but containing decorative aggregates and often pigment.

Fibre - An individual glass filament with an average diameter of 13 to 20 microns and not less than 9 microns in diameter.

Fibre Content - The ratio, usually expressed as a percentage, of the glass fibre to the total composite; it can be by weight or volume.

Flex Anchor - A steel connection between the GRC panel and the supporting stud frame in stud frame construction. It is usually designed to provide lateral restraint only against the effects of wind forces and seismic loadings whilst allowing rotation perpendicular to the GRC facing.

Glassfibre content by weight (WF) - The ratio (expressed as a percentage) of the mass of glassfibre to the mass of GRC in the uncured state.

Gravity Anchor - A steel connection between the GRC panel and the supporting stud frame in stud frame construction. It is usually designed to support the full weight of the GRC panel and is positioned close to the bottom of the GRC panel.

GRC/GFRC Glass(Fibre) Reinforced Concrete.

GRCA - Glass Reinforced Concrete Association.

GRCA Approved Manufacturers Scheme AMS - The GRCA system of accreditation by assessment of the ability of a manufacturers to provide the necessary resources and equipment to meet the quality level required of GRC products.

High Shear Mixer - A mixer with a high shear action capable of the preparation of the fine sand/cement slurries required for the spray process.

LOP - Limit of Proportionality (flexural) ie the point at which the stress/strain curve deviates from a straight line.

Matrix - The cement paste into which various amounts of aggregate particles and/or glass fibres are incorporated.

MFFT - Minimum film formation temperature (for acrylic polymers).

Mist Coat - An initial cementitious sprayed coating without glass fibre.

MOR - Modulus of Rupture (flexural), the ultimate bending stress obtained from the four point bend test.

Premix GRC - A method of manufacture in which pre-cut glass fibres and the cementitious slurry are blended during the mixing.

Premix Mixer - A two stage mixer designed to prepare fine sand/cement slurries (Stage 1) and to blend in chopped glass fibres (Stage 2).

Polymer-Modified GRC - GRC which has been modified by the addition of an acrylic thermoplastic polymer dispersion either for 'dry curing' or for property enhancement.

Producer - The person or authority entering into a contract to manufacture a GRC product.

Purchaser - The person or authority entering into a contract to buy a GRC product.

Roving - A group of parallel glass fibre strands wound as a bundle with a cylindrical shaped package.

Roving Tex - The mass of "chopped" glass strands per kilometre length.

Sand/cement ratio - The ratio of the mass of the total dry sand to the mass of dry cement in the GRC

Sandwich Panel - A prefabricated panel which is a layered composite formed by attaching two skins separated by an insulating core or cores.

Scrim - A manufactured fabric having open area construction of over 4mm using AR glass fibre strands. It is laid up by hand to reinforce an area of the GRC backing.

Seismic Anchor - Bars or plates that transfer the seismic load on the skin back to the stud frame.

Serviceability Limit State - The condition of the GRC panel during use ie when in service. This usually refers mainly to allowable deflection limits when checking the conformance of GRC to this limit state.

Slump Test - A test for measuring the consistency of the cementitious slurry.

Spray GRC - A method of manufacture in which the GRC is produced by simultaneously spraying cementitious slurry and chopped glass fibre.

Stiffening Rib - A local thickening of the GRC skin to give the panel additional stiffness and strength.

Stud Frame - A structural framework, usually steelwork, to support a GRC panel by means of flex anchors and gravity anchors. This frame is attached directly to the supporting structure.

Superplasticizer - A high range water reducer admixture producing a cement slurry of significant higher slump without additional water.

Supplier - The person or authority entering into a contract to supply goods or services to the producer..

Test Board - A sheet of GRC manufactured during production for the purpose of assessing the quality of the GRC products being made. The test board should, if possible, be a specimen of the product itself. If this is not possible the test board should be made in the same way and at the same time as the GRC in the product so that it is representative of the quality and thickness of the GRC.

Test Board Mean - The arithmetic mean value of a property calculated from individual test results from one test board. For statistical analysis this mean is regarded as one result.

Test Coupons - Specimens taken from a test board for determining a property.

Test sample - The total number of coupons taken from a test board and tested to determine a property of that test board.

Tolerance - A specified permissible variation from stated requirements such as dimensions and strength.

Trowelled Surface - The surface of a panel away from the formwork or mould made by smoothing with a trowel.

Ultimate Limit State - The state of collapse. Conformance with this limit state is checked using a number of partial factors of safety applied to both the GRC mix and the applied loading.

Ultimate Tensile Strength - Stress at which GRC fails in pure tension.

Uncured state - The stage in manufacture of GRC when all the physical processes that could alter the composition of the material are complete but the fibre can still be separated from the matrix by the action of running water.

Water/cement ratio - The ratio of the mass of total water(including water contained in the polymer and plasticiser) to the mass of dry cement.

The material properties, component design and method of manufacture of GRC products are interrelated

1.3 Types of GRC

Glass Reinforced Concrete (GRC) is a composite material consisting of a mortar of hydraulic portland cement and fine aggregate reinforced with alkali resistant glass fibres. Within this broad definition, variations are possible in mix constituents and proportions, and manufacturing method, such as to produce materials with differing properties. The material properties, component design and method of manufacture of GRC products are interrelated.

The properties of GRC depend on a wide range of variables. These include method of manufacture, mix formulation, fibre product type, length and orientation, admixtures used, etc. A GRC material may therefore be tailored to meet the particular requirements of a specific application. The information given in this guide mainly refers to GRC materials having an aggregate:cement ratio of up to 1:1, incorporating AR glassfibres in the range 2 - 5% and made by the spray and premix processes. The GRC may contain additional filler materials and admixtures. GRC materials have been widely used for a number of years and their properties and characteristics studied extensively.

GRC is a family of composite materials that combine the high compressive strength properties of cement mortars with significantly increased impact, flexural and tensile strengths imparted by the fibre reinforcement. GRC is a composite with reinforcing elements randomly distributed throughout the matrix, unlike reinforced concrete where the reinforcing steel is placed primarily in tensile stress areas, at a predetermined distance from the surface to give the steel protective cover. This means that for practical purposes GRC is designed as a homogeneous material.

GRC products are safe, have good chemical resistance and will not rot or corrode. GRC is made of inorganic materials, will not burn and has negligible smoke emissions. It gives excellent stability and integrity resistance to fire. However, due to the thin nature of panels, it requires additional material to satisfy insulation requirements. In some circumstances GRC is made containing polymer materials which may slightly affect some fire performance properties.

GRC is normally of relatively thin cross section, with thickness commonly in the range 10mm to 15mm. This gives a low component weight which allows savings in handling, storage, transportation, and installation compared with traditional concrete products.

There are two main methods of manufacturing GRC, namely:

(i) **Spraying** the fibre and slurry simultaneously onto a mould, by manual or mechanical means, with subsequent compaction by roller and trowel. Typical products made using the spray process include architectural cladding panels, channels, tanks, facade elements, ducting and permanent formwork.



Figure 1.1

Initial spraying mould with a mist coat



Figure 1.2
Spraying GRC into mould



Figure 1.3
Compacting GRC using serrated roller



Figure 1.4
Gauging thickness of GRC



(a)



(b)

Figure 1.5

(ii) **Premixing** pre-chopped fibre in a mixer after thorough mixing of other components and then processing the mixture by vibration casting in a mould, extrusion, injection moulding etc, to produce the end product form (Figures 1.5(a) and (b)). This method of production is very versatile and is ideal for producing small items of architectural product in short periods of time, by using multiple moulds.

1.4 Selection of Production Method & Raw Materials

The raw materials and mix design, and production method used, are decided according to the particular product and are inter-related with the engineering design. In choosing the mix design the following may be varied: fibre content and type; sand/cement ratio; water/cement ratio; polymer content. By varying the composition of the cementitious slurry and the percentage of fibre a range of materials with differing mechanical and physical properties may be produced. These different mechanical and physical properties must be considered by the designer and manufacturer and the appropriate type of GRC selected for the application.

1.4.1 AR Glassfibre

AR (Alkali Resistant) glassfibre is specially formulated to have a high degree of resistance to alkali attack and high durability in cement. Cement solution is highly alkaline (typical pH12.9) which is a very aggressive environment for glass fibres. 'E' glass fibres, as used in plastics reinforcement, are rapidly destroyed. The special formulation of the 'AR' fibre, in particular the zirconia content, resists this aggressive environment. Laboratory testing shows that at least 16% zirconia content is required for adequate alkali resistance.

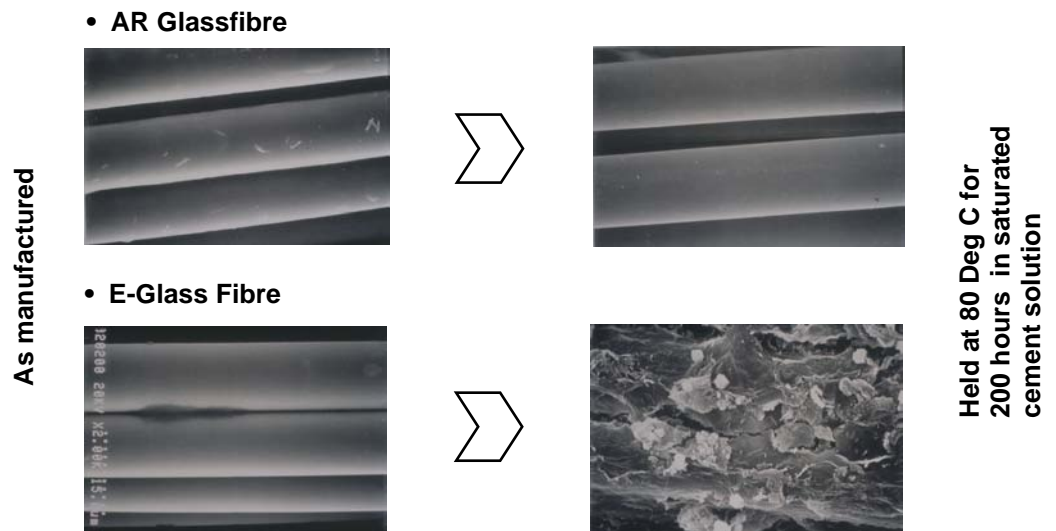

Figure 1.6 - Comparison of Alkali Erosive Attack in AR and E Glass Fibre

AR fibres are originally produced as continuous filaments typically 13 –20 microns in diameter and these filaments are gathered together to form strands. A coating or size is used to bind the filaments together. The number of filaments forming the strand and the type of size can be varied to produce a range of glass fibres to suit particular applications.

Typical AR Fibre Properties

- | | |
|-------------------------------------|-----------------------------|
| • Single filament tensile strength | 3.0 - 3.5 GN/m ² |
| • Strand tensile strength | 1.3 - 1.7 GN/m ² |
| • Young's Modulus of Elasticity | 72 – 74 GN/m ² |
| • Specific Gravity | 2.60 - 2.70 |
| • Strain at breaking point (strand) | 2.0 - 2.5% |
| • Filament diameter | 13 - 20µm |

Table 1.1 - Typical Specification

Property	Specification Value	Method of Test	Frequency of Testing
Zirconia Content	16% Minimum	X-Ray Fluorescence Analysis	Monthly
Density	2.7 +/- 0.3 G/cm ³	ASTM D 3800	Yearly
Tensile Strength (Strand)	1.0 - 1.7 GN/m ²	ASTM D 2343 Strand	Yearly
Filament Diameter	9 to 20 +/- um		Each 20 Tonnes
Roving Tex	+/- 10% from the nominal value stated by the Supplier	ASTM D 861	Each 20 Tonnes
Cut Length	+/- 3mm from the nominal value stated by the Supplier		Each 20 Tonnes
End Count	+/- 20% from the nominal value stated by the Supplier	Physical Count	Each 20 Tonnes
Loss on Ignition	+/- 20% from the nominal value stated by the Supplier, or +/- 0.3%, whichever is the greater		Each 20 Tonnes
Strength Retention by Strand in Cement	Minimum value 330 N/mm ² after 96+/-1 hour in water at 80 deg C (+/- 1 deg C)	'Method of Test for Strength Retention of Glass Fibre in Cements and Mortars'. GRCA SO104/0184, Jan 1984	Monthly

The above tests are carried out by the glassfibre manufacturer.

There are two main product forms used for GRC production. These are Chopped Strands for use in premix GRC, and Rovings for use in the spray production.

Chopped Strands consist of continuous strands cut to uniform length while maintaining the integrity of the original strand. The size or coating on Chopped Strand products are designed to give resistance to mechanical damage in processing particularly during mixing.

Rovings are groups of individual parallel strands wound as a bundle into a cylindrical shaped package containing typically 18 to 20 kg of fibre. It may be:

- 1) chopped in a 'gun' and sprayed simultaneously with the cement matrix material onto or into a mould.
- 2) chopped on-site for use in the premix process.

Nets, scrimms, chopped strand mat, and sewn fibre products are also available for applications where positioned or directional reinforcement is required.

1.4.2 Cement

The most widely used cements in GRC manufacture are Ordinary Portland Cement (OPC) Rapid Hardening Portland Cement (RHPC) and White Portland Cement. They should conform to the relevant National or International Standards. European equivalents to British Standard cements (CEM I to CEM V) have been recently issued. RHPC is chemically very similar to OPC but is more finely ground and, because of this, develops strength more rapidly at early age.

White Portland cement is made from raw materials containing only a very small quantity of iron. It is used in GRC where a white or light coloured finish is required. Other types of cement, such as High Alumina Cement, Sulphate Resistant and Rapid Setting Cements may be used in certain applications and should be to the relevant Standard. Care should be taken that the choice of cement is appropriate to the product and complies with statutory regulations.

It is important that cement is correctly stored . Cement must be kept dry, and damp air can be as harmful as direct moisture. Cement stored in bulk in a silo will be satisfactory up to about 3 months. Cement in normal 3-ply paper bags stored under good conditions can lose about 20% of its strength after 4 to 6 weeks. Therefore, bagged cement should be used soon after delivery and in order of age.

1.4.3 Sand

Fine aggregate or sand should be supplied washed and dried to remove soluble matter and permit accurate control of the water/cement ratio. The particle shape should be round or irregular and should have a smooth surface without honeycombing.

For spray GRC, the maximum particle size is generally limited to 1.2 mm; for premix GRC, the maximum particle size may be 2.4 mm. In both cases the fine fraction, i.e. sand passing a 150 micron sieve, is preferably less than 10% of the total weight of sand.

Silica sands are widely used, a typical specification being:

Silica content		> 96%
Moisture content		< 2%
Soluble salts		< 1%
Loss-on-ignition		< 0.5 %
Sulphate ion	maximum	4000 ppm
Chloride ion	maximum	600 ppm

Sands with a higher moisture content may be used provided the moisture content is known and the mix design is altered accordingly.

Sands other than silica sands may be used but the producer should provide evidence of their suitability. Soft building sands must not be used as they may lead to inferior mechanical properties. The silica content of the sand need not necessarily be as high as 96%. There are good quality sands with much lower silica content that are suitable for GRC manufacture.

The value for loss on ignition can be accepted up to 3%, providing the material is hard, non crushable (to obtain optimum mechanical properties and to preserve grading as a breakdown of particles would increase water demand), non-reactive and of similar shape and grading to that described above.

1.4.4 Sand/aggregate facing mixes

When a facing mix is used to produce an architectural finish special aggregates and sand may be required. The colour of the aggregate is particularly important as this contributes to the overall appearance. The grading differs from the sand used in the GRC mix with 0-3mm typically being used when the facing layer is sprayed and up to 10mm when the facing layer is poured and vibrated. Mix design may differ from the GRC backing layer but consideration should be given to potential differential shrinkage as a result of different cement content. Crushed and graded hard rocks like limestone, granite, spar, calcite or marble are particularly suitable.

1.4.5 Admixtures

The use of admixtures, such as plasticisers and superplasticisers, is encouraged as they can enhance the properties of GRC. Standard concrete admixtures or those specially formulated for GRC manufacture may be used as appropriate. Admixtures are generally added to produce the following effects.

In the manufacture of GRC :

- increasing the workability without increasing the water/cement ratio
- improving the cohesion
- reducing segregation
- reducing bleeding
- retarding the setting (stiffening) process
- accelerating the setting (stiffening) process.

On the properties of hardened GRC :

- increasing the rate of early strength development
- increasing the strength
- decreasing the permeability

Admixtures are added to mixes in small amounts and care must be exercised to ensure that only the correct dose as specified by the manufacturer is added.

Calcium chloride based accelerators must not be used if the GRC product contains any steel components (or fixings) as there is a risk of corrosion of the metal.

1.4.6 Acrylic Polymers

Cementitious products should be moist cured to ensure that there is sufficient retained moisture for complete hydration of the cement. This is particularly critical for thin skin GRC products. The recommended curing regime is a wet cure at 95% relative humidity for 7 days. In many cases this is not practical as insufficient factory space is available.

Acrylic Polymers are added to the GRC mix to allow for a subsequent dry cure and for property enhancement, particularly the reduction of surface crazing.

When acrylic polymers are added to the mix at the recommended dosage a film is formed within the matrix during the first few hours of curing. The formation of this film significantly reduces the permeability and thus lessens the loss of water by evaporation ensuring that sufficient water is available for complete hydration.

Table 1.2 - Typical Polymer Specification

Compound Type	Aqueous thermoplastic polymer dispersion
Polymer Type	Acrylic based
Minimum Film Formation Temperature	7 - 12 deg C
% Solids	45 - 55%
Appearance	Milky white, creamy, free from lumps
Ultraviolet Resistance	Good
Alkali Resistance	Good

1.4.7 Water

Water should be clean and free from deleterious matter and should meet relevant standards for water to be used to make concrete. Potable water is normally suitable.

1.4.8 Pozzolanic Materials

PFA ,GGBS, Metakaolin and Microsilica are a range of pozzolanic materials which have been shown to have a beneficial effect on the properties of GRC. They work by reacting with the free lime produced during the hydration process to form further hydration products.

1.4.9 Pigments

Powder pigments or dispersions may be used to produce coloured GRC . The pigments are normally iron oxide based and should conform to national or international standards. It is normally found that less intense, pastel shades are more successful and some variability is to be expected.

1.4.10 Paints, sealers and adhesives

Suitable paint coatings and adhesives may be used with GRC products. It is important to select a coating product which is appropriate: normally a product that is designed for use on concrete will perform adequately. As a general rule paint coatings used should be permeable to moisture vapour. Manufacturers' recommendations on the preparation of the GRC surface, and priming procedures, should be followed strictly.

1.5 Applications and Uses

GRC has many applications in both the architectural and civil engineering sectors of the construction industry, where both the functional and decorative qualities of the material are used. It is a particularly attractive and durable cladding material. GRC can be moulded into a variety of complex shapes and profiles, with a choice of attractive finishes, and is ideally suited to the popular fast-track approach of using lightweight, prefabricated cladding panels for the exterior of modern buildings. The main advantage of GRC panels over the corresponding precast alternatives is the considerable saving in weight. This results in significant savings in the cost of transportation, handling and erection of the panels. If this weight advantage is considered at the design stage, economies may be possible in the design of foundations and the superstructure of high rise buildings. Other notable advantages of GRC cladding are its durability, chemical resistance, good fire performance and good sound and heat insulation properties. A few examples can be illustrated as follows:



Figure 1.7
Architectural Cladding



Figure 1.8
Industrial Cladding



Figure 1.9
Architectural Features



Figure 1.10
Sunscreens



Figure 1.11
Renders

In civil engineering, agriculture and landscaping, many of the same properties are utilised, notably resistance to environmental conditions, adequate strength in thin section, ease of handling, and maintenance-free performance throughout service life.



Figure 1.12
Artificial Rocks



Figure 1.13
Noise Barriers



Figure 1.14
Ducts & Channels



Figure 1.15
Permanent Formwork



Figure 1.16
Agricultural Products



Figure 1.17
Street Furniture



Figure 1.18
Sewer Lining



Figure 1.19
Utility Boxes

The qualities of GRC can therefore be summarised as:

- Attractive and Versatile - Can reproduce fine surface details and finishes to complement any architectural style.
- Light Weight
 - Easier to transport and install
 - Reduces structural and foundation costs
- Good Chemical Resistance
- Will not Rot or Corrode
- Low Maintenance
- Unaffected by UV light or Hot Dry Conditions
- Suitable for any climate
- Freeze/Thaw Resistant

2

PHYSICAL PROPERTIES OF GRC

GRC is not a single material and its properties can be varied to suit the end use. The design process should recognise this and specify the grade of GRC based upon the required physical properties. The physical properties of GRC are dependent on the composition of the cementitious slurry, the fibre content and the method of manufacture and curing.

The GRCA classifies GRC into 3 grades of material based on the 28 day flexural strength.

These are Grade 18, Grade 10 and Grade 5 and there are significant differences between them as illustrated by the following load deflection curves.

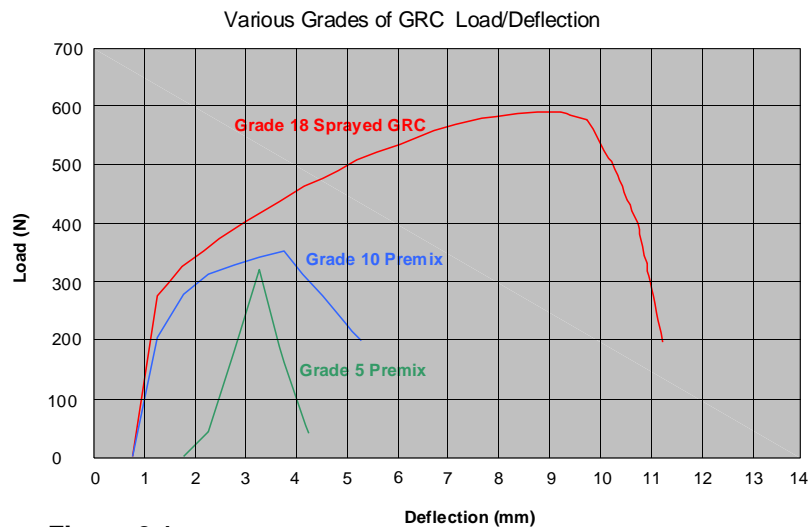

Figure 2.1

The importance of selecting the appropriate grade consistent with the application and the engineering design of the product cannot be over-emphasised.

2.1 Effects of Mix Composition and Fibre Content

The simplest mix design of GRC contains cement, sand, water, superplasticiser, and alkali resistant glass fibre.

Variations such as the use of pozzolanic cement replacements (PFA, Pulverised Fuel Ash) are common in a number of countries and acrylic polymer emulsions are widely used to allow “dry curing”. Pigments can be used to impart colour as with traditional concrete.

In terms of effect on strength properties, the quantity and form of AR glass fibre used in the GRC is a significant factor, linked to the process by which it is introduced. Sprayed GRC is the strongest material and typically incorporates 4-5% of glass fibres, of length 25 - 40mm. GRC manufactured by the premix (vibration casting) method typically incorporates between 2% and 3.5% of glass fibres by weight, of usual length 12 - 13mm.

2.2 Flexural Strength.

General

Flexural strength is probably the most important physical property of GRC. It is the property that is most frequently tested and is the property on which most designs are based. Whereas concrete would be referred to in terms of its compressive strength e.g.

Values cannot be assumed and flexural testing should be a part of a quality assurance programme for all manufacturers.

C40/50, GRC is categorised by its flexural strength. Grade 18 would mean a characteristic flexural strength (Modulus of Rupture) of 18N/mm² at 28 days. The flexural strength depends on many factors, glass percentage, mix design, method of manufacture and curing all being important. Values cannot be assumed and flexural testing should be a part of a quality assurance programme for all manufacturers.

Test Method

The flexural strength of GRC is tested using a four point bending test. The test is described in “GRCA Methods of Testing Glass Fibre Reinforced Cement Material” and the following standards:
 BS EN 1170 PARTS 4 and 5
 ASTM C947 MODIFIED

Table 2.1 - Test Values at 28 days

Type of GRC	LOP (N/mm ²)	MOR (N/mm ²)
Sprayed	5 - 10	18 - 30
Premix	5 - 10	5 - 14

2.3 Tensile Strength

General

Historically it has proved difficult to achieve reproducibility from tensile testing results on GRC samples and because of this the flexural test has assumed more importance. Tensile testing is not normally carried out as part of routine quality control.

Test Method

There is no standardised test method although there are published research papers on the subject.

Table 2.2 - Test Values

Type of GRC	BOP (N/mm ²)	UTS (N/mm ²)
Sprayed	4 - 6	8 - 12
Premix	3 - 5	3 - 6

2.4 Shear strengths

General

Testing for Shear strengths is not part of routine testing although for some products it can be a significant factor in design. This is particularly the case with the bearing of permanent formwork, in webs or ribs of single skin cladding and for fixings.

Test Method

No specific method for GRC

Table 2.3 - Test Values

Type of GRC	Punching Shear (N/mm ²)	In Plane Shear (N/mm ²)	Interlaminar Shear (N/mm ²)
Sprayed	25 - 35	7 - 12	2 - 4
Premix	4 - 6	4 - 6	4 - 6

2.5 Shrinkage and Creep

General

Shrinkage

All cement based materials are susceptible to dimensional changes as they are wetted and dried. After manufacture and cure, shrinkage from the original state occurs as drying takes place. Re-wetting results in expansion but not to the extent of restoring the original size: there is therefore an initial irreversible shrinkage, which will be followed in subsequent service conditions by a reversible dimensional movement dependent on the moisture content of the cement. For GRC the irreversible shrinkage is one quarter to one third of the total possible shrinkage: typical figures for a 1:1 sand:cement ratio GRC mix are 0.03% irreversible shrinkage and a total ultimate shrinkage of about 0.12%. The shrinkage and moisture movement behaviour are represented diagrammatically

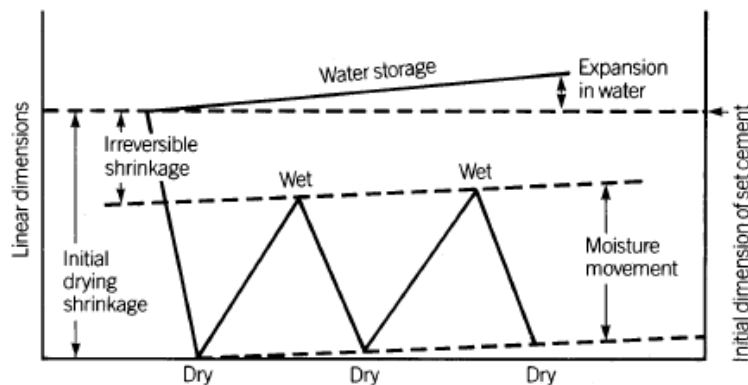

Figure 2.2a - Diagrammatic representation of moisture movements.

It should be noted that the amplitude of reversible movement quoted above is between fully-dried and fully-soaked conditions, as in the laboratory. In practice these extremes may not be experienced in normal weathering conditions although there will be some cyclic movement about a mean level which is effectively shrunk relative to initial manufactured dimensions.

The moisture content of the material is related to the relative humidity of the surroundings, so it is convenient to express the dimensional change in terms of relative humidity. Figure 2.2 (a) shows the reversible shrinkage obtained when neat cement GRC is completely dried from equilibrium with any value of relative humidity (based on published data).

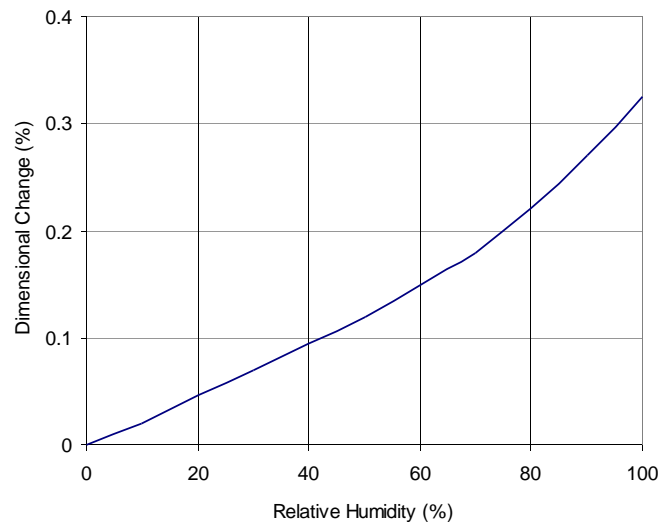

Figure 2.2(b)

Test Method

BS EN 1170 -7

Values

Total ultimate shrinkage up to 0.2% depending on mix design.

Design Values

An understanding of the magnitude of shrinkage and moisture movements is fundamental to the design process particularly with regard to the fixings. In general an allowance of 1 to 1.5 mm per metre of product dimension must be allowed for in terms of joint design and fixing movement.

2.6 Impact Resistance

General

GRC resists Impact loads very well and when damage does occur it is restricted to a localised area. The presence of the fibres in GRC restricts the propagation of cracks outside the zone of stressed material. This damage can often be repaired with no detriment to the GRC products.

The impact strength of GRC is high when many long fibres fail by being pulled out of the matrix, this process absorbing a great deal more energy than fibre breakage. The impact strength of GRC is lower when few fibres are pulled out of the GRC. If the fibres have a very short critical length the GRC may exhibit brittle characteristics under impact loads.

Test Method

Impact strength of GRC is normally measured using a modified Izod or Charpy test machine, on samples 25-50 mm wide and 6-12 mm thick. The values obtained in such a test are not readily used in any design calculation but are useful for the purpose of comparison with samples of GRC and other materials subjected to the same test. Such comparisons show the impact strength of GRC to be higher than that of many similar materials.

Of more significance is testing done on actual products to simulate real conditions that the product may have to face. These tests are product specific and often designed to cover one set of circumstances with the impact load being supplied by either a dropping or swinging weight.

Table 2.4 - Typical values obtained at 28 days

Type of GRC	Charpy Impact Strength (N/mm/mm ²)
Sprayed	15 - 25
Premix	7 - 12

Design Values

Calculations are difficult and so are rarely performed. As above, Impact Strength of GRC is good and is not normally a significant factor in design.

2.7 Density, Water Absorption and Permeability

General

The density of standard GRC materials is commonly around 2000 kg/m³ which is below that of conventional dense concrete. GRC forms lightweight components by virtue of thin section, rather than by lightness of the material; although low-density versions of the material are possible.

The significance of density, however, goes beyond the simple concept of weight. Density is a good indicator of material quality, a high density meaning slightly greater fibre volume fraction but more significantly indicating well-compacted, well-made material of correct water:cement ratio.

Water absorption and apparent porosity figures are higher than those for typical concrete, which would normally exhibit a water absorption less than 10%. This is a direct result of the higher cement content in GRC. The permeability of GRC, is however significantly lower than that of concrete.

GRC is a waterproof material and is used for water retaining structures. GRC cladding panels withstand windblown rain under the severest of conditions.

Test Method

The Density, Water Absorption and Apparent Porosity are all determined in the same test which is carried out as part of routine Quality Control testing .
 “ GRCA Methods of Testing Glass Fibre Reinforced Cement Material” and the following Standards.

BS EN 1170 PART 6
 BS6432
 ASTM C948

The water vapour permeability can be tested according to BS 3177 although this is by no means a routing test.

Table 2.5 - Typical Values at 28 days

Type of GRC	Dry Bulk Density (Tonne/m ³)	Water Absorption (%)	Apparent Porosity (%)
Sprayed	1.8 - 2.1	8 - 13	16 - 25
Premix	1.8 - 2.0	8 - 13	16 - 25

2.8 Fire Resistance

General

GRC is a fire-safe material. Many GRC mix designs do not contain any organic materials other than very small amounts of superplasticiser and trace quantities of binder on the glass fibres. These formulations comply with the Non-Combustibility criteria for national and EU test standards. GRC that contains acrylic polymer for curing purposes also performs well, although not normally classified as Non-Combustible. When tested for Ignitability, Fire Propagation and Surface Spread of Flame it achieves the highest possible ratings and conforms to the requirements for Class O defined by the British Building Regulations. In all cases the smoke emission is very low and the emission of toxic fumes is minimal.

When GRC is used in a panel construction the Fire Resistance achieved depends on the whole of the construction. Single layers of GRC do not have guaranteed Integrity in the usual fire resistance tests unless the GRC mix design has been modified to allow the GRC to release moisture vapour easily during the initial part of the test procedure. Panels using GRC in conjunction with other materials have been designed and tested to give Fire Resistance of up to 4 hours.

2.9 Sound Insulation

GRC obeys the **Mass Law** for sound transmission loss through a partition. Below about half the critical frequency, sound transmission loss is generally only related to the mass of a material or partition. Mass law helps quantify the sound transmission loss at these frequencies. At these frequencies, doubling the mass per unit area of a partition panel, or doubling the frequency for a given mass per unit area, increases the sound transmission loss by 6 decibels in the frequencies controlled by mass law.

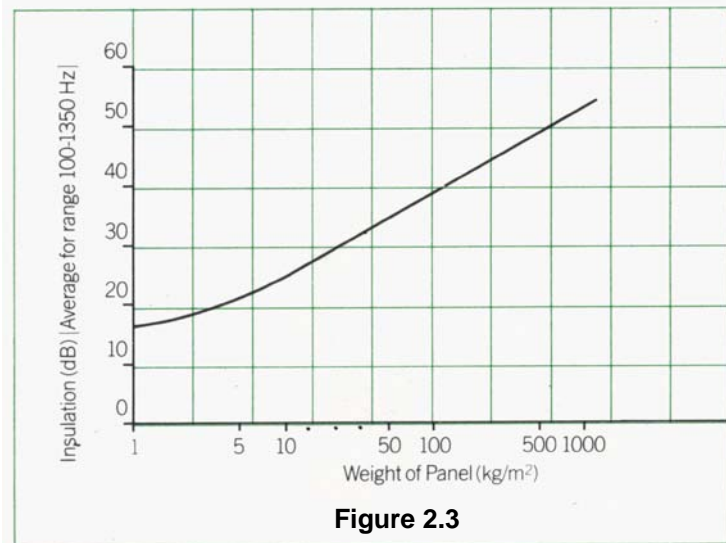

Figure 2.3

A significant reduction in sound transmission loss (i.e., a significant increase in the transmission of sound) through a partition occurs at the **critical frequency**. The critical frequency is the frequency at which the wavelength of sound in air equals the flexural bending wavelength in the partition or material. The critical frequency therefore depends on the fixing system used (Figure 2.3).

GRC is often used for Sound Barriers for roads and railways. The Mass Law does not work for these barriers and there is little benefit in increasing the surface mass above the minimum required for resistance to wind loading because of **diffraction**. This is the distortion of a wavefront caused by the presence of an obstacle (barrier) in the sound field. Above 12 kg/m² there is no useful improvement (Figure 2.4).

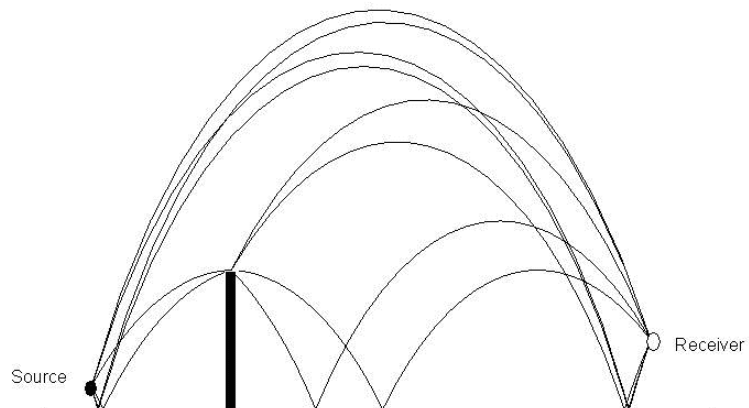

Figure 2.4

Since 20 kg/m^2 is the surface mass of 10mm GRC, any GRC panel designed to resist wind load will be heavy enough to give useful performance as a sound barrier material.

GRC sound barriers can either be:

Absorptive where an open grille at the front is backed up with sound absorbent material and a final layer of GRC (Figure 2.5).



Figure 2.5

or

Dispersive where the surface of the GRC sound barrier panels is shaped such that the reflected sound interferes with itself and is therefore reduced in intensity (Figure 2.6).



Figure 2.6

2.10 Thermal Insulation

General

GRC with a typical density of $1900\text{-}2100 \text{ kg/m}^3$ has a thermal conductivity in the range of 0.5 to $1 \text{ W/m}^\circ \text{C}$ depending on moisture content. This means that GRC is not itself a good thermal insulation material. However, the design of either single skin or stud frame GRC cladding panels allows insulating materials to be incorporated without increasing the overall panel thickness.

When a particular 'U' value is required, the calculations of thermal resistance should be carried out by a specialist.

2.11 Resistance to Carbonation

General

Carbonation in GRC is not considered significant. GRC products do not normally contain mild steel reinforcement and so cover to the steel is not an issue. GRC has been shown to carbonate at a very slow rate when compared to concrete and some studies have found no evidence of carbonation at all. The low carbonation rate of GRC compared to normal concrete is due to the comparatively high cement content and low permeability of GRC. The data shown below is taken from work carried out by the British Cement Association on the use of GRC as permanent formwork. In this application GRC has the benefit of protecting the reinforcing steelwork from corrosion by protecting the concrete from carbonation (Figure 2.7).

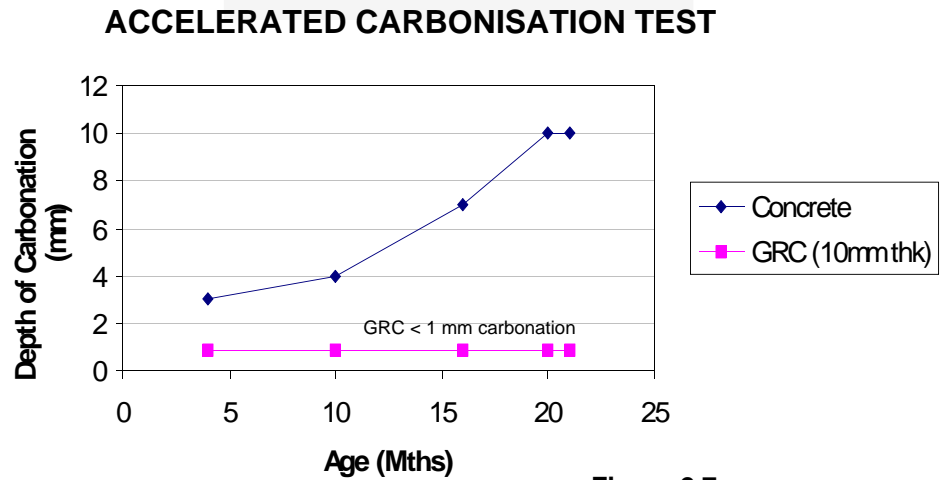

Figure 2.7

2.12 Thermal Expansion

GRC has a thermal expansion of $10-20 \times 10^{-6}/^{\circ}\text{C}$. The minimum values occur at high and low Relative Humidities. The maximum values occur around 50-80% RH. This should be considered along with moisture and shrinkage movements when designing GRC products.

Table 2.6 - Summary of Mechanical Properties at 28 days

Description	Hand Sprayed	Premix
Modulus of Rupture (MOR_{28}) in N/mm^2	18 - 30	5 - 14
Limit of Proportionality (LOP_{28}) in N/mm^2	5 - 10	5 - 10
Ultimate Tensile Strength (UTS_{28}) in N/mm^2	8 - 12	3 - 6
Bend Over Point (BOP_{28}) in N/mm^2	4 - 6	3 - 5
Interlaminar Shear in N/mm^2	2 - 4	N/A
In-Plane Shear in N/mm^2	7 - 12	4 - 6
Punching Shear in N/mm^2	25 - 35	4 - 6
Charpy Impact Strength in $\text{N}/\text{mm}/\text{mm}^2$	15 - 25	7 - 12
Dry Bulk Density in kg/m^3	18 - 21	18 - 20
Water Absorption (%)	8 - 13	8 - 13
Apparent Porosity (%)	16 - 25	16 - 25

2.14 Long-Term Time Dependent Properties

The properties of GRC are stable in dry conditions but most GRC formulations lose a proportion of their strength over extended periods in damp/wet conditions. This is well documented. Properties such as Ultimate Bending/Tensile strength and Strain to Failure decline to stable levels. The design stresses used are less than the predicted long term strengths and less than the matrix cracking strength (LOP). The LOP tends to rise slightly with time because of continuing cement hydration (Figure 2.9).

GRC does not suffer from cyclic stress fatigue as long as the stresses are below the LOP.

Some specialist GRC formulations exhibit very little property changes with time.

An important point in design and erection is to ensure that the fixing systems allow for in-service moisture and thermal movements. If these small movements are restrained the GRC may become over-stressed and cracking may occur.

The surface of GRC cladding panel or moulding may require cleaning depending on the design and environment and should be regarded as being similar to concrete. Some applied finishes have a limited lifetime and may require maintenance.

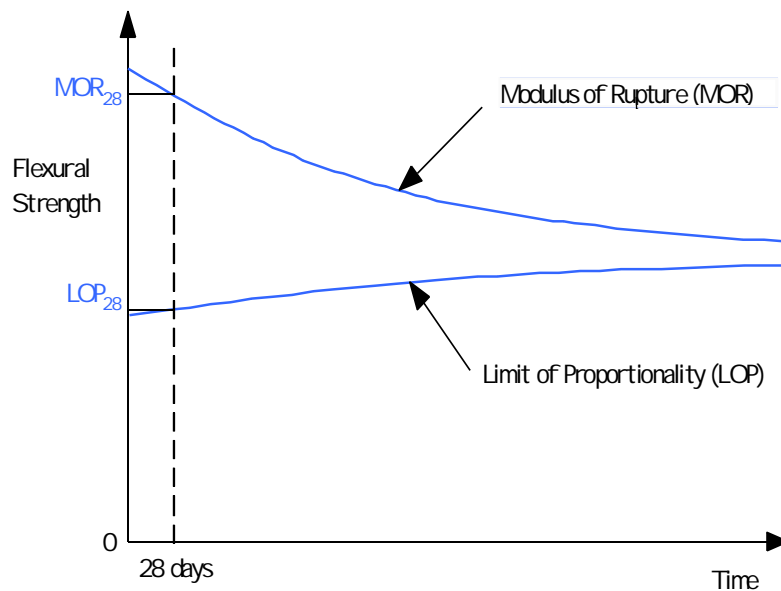

Figure 2.9

3

TYPES OF PANEL CONSTRUCTION

At an early stage the Designer must decide the basic form the GRC element will take to satisfy the performance requirements. This choice is closely related to the production method and materials, and to the fixing method ultimately to be used.

The simplest form of GRC panel is a single skin, typically between 10 to 15 mm thick. However, design requirements or panel size may call for a thicker GRC skin, or the use of stiffeners. The minimum design thickness of the GRC skin would not normally be less than 10 mm for an architectural application.

Unless the panel has a shape which in itself contributes to the panel strength and stiffness, GRC properties dictate the use of a design which increases the load-carrying ability on panels of any appreciable size. Methods commonly used include:

- Up-standing single skin edge returns formed on the back of the panel.
- Integral ribs formed on the back of the panel by spraying over hidden rib formers, such as expanded polystyrene strips.
- Prefabricated, cold-formed steel studs or structural tubes (stud frame system).
- A sandwich construction, where GRC surrounds a lightweight insulating core, such as expanded polystyrene.

Each of these methods provide greater capacity, for example to span between supports against wind loading, and provide a means to connect the panel to the supporting structure.

3.1 Single Skin Construction

3.1.1. Simple Single Skin Panels

For relatively small panels, which have some degree of shape to give them stiffness and strength, it is normal to use a single skin of GRC which is thickened in the vicinity of the fixings. These panels would normally use edge returns around the perimeter to assist jointing, and also to contribute to the panel's strength. This is a simple and economic method of construction for small or shaped panels (see Figure 3.1).

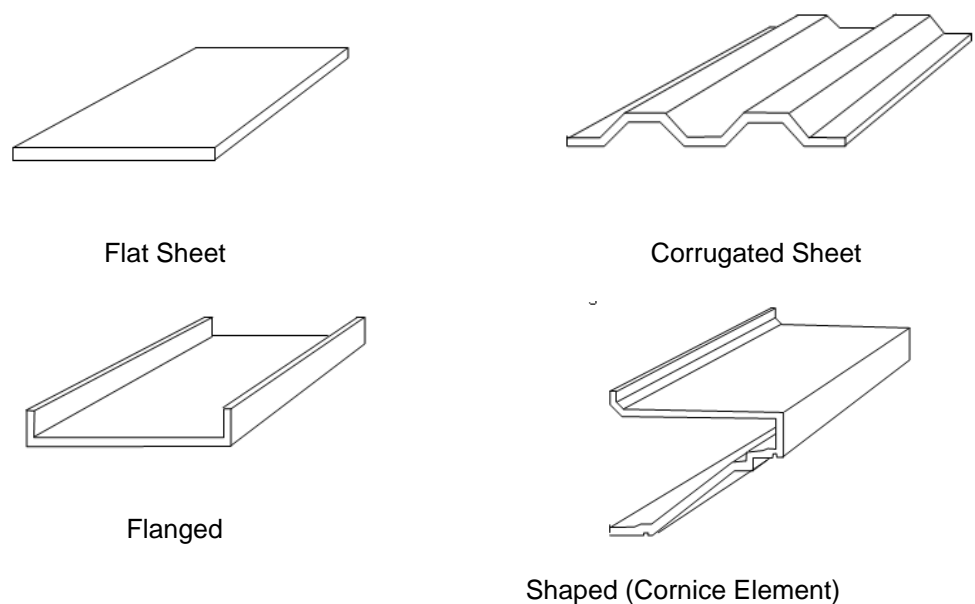

Fig 3.1 - Types of Single Skin Panels



Figure 3.2 Flat single skin panel.

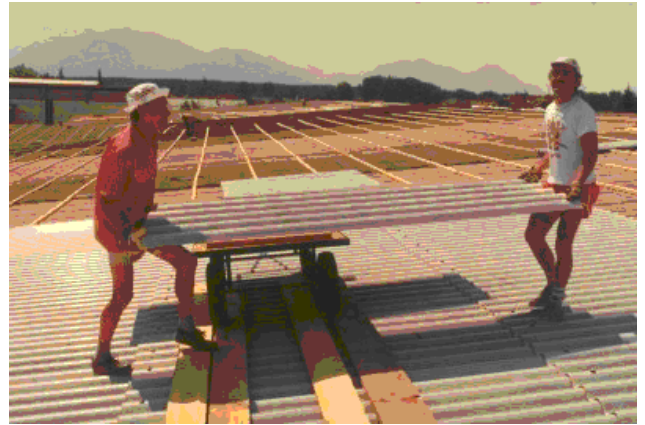

Figure 3.3 - Corrugated, single skin panel

3.1.2 Ribbed Single Skin Panels

For larger panels, if a steel stud frame is not being used, it will be necessary to build stiffening ribs into the panels. The principal is to position GRC away from the neutral axis of the panel, and into the regions of tensile and compressive stress. At the neutral axis, the GRC gives little contribution to strength or stiffness of the panel, whereas in the tensile and compressive regions, it is able to give a valuable contribution to the strength and stiffness of the panel.

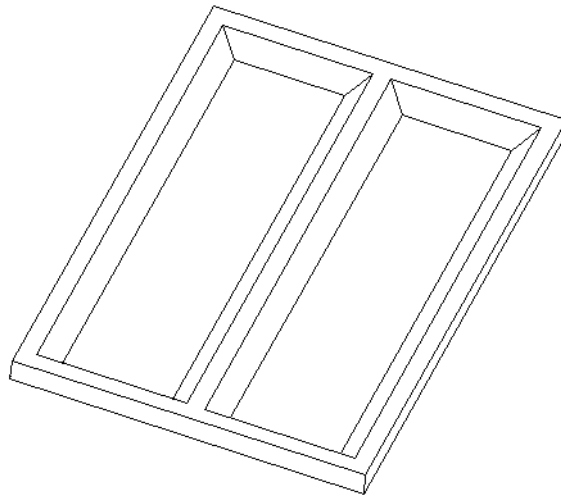

Figure 3.4 - Ribbed, Single Skin Panel

This principal is achieved by spraying GRC over rib-formers, which are normally be made from polystyrene or preformed GRC section. These ribs would be positioned around the perimeter of the GRC panel, where they will also give the panel sufficient depth to allow jointing, and in some instances they will also run across the panel.

3.2 Stud Frame Construction

Instead of using GRC ribs and stiffeners it is possible to use a frame, most commonly in steel. The stud frame provides support to the skin whilst permitting thermal and moisture movements. This form of construction has gained popularity particularly when very large and generally flat panels are to be made. The stud frame system allows panels of 10-20m² to be manufactured, transported and erected.

A GRC stud frame cladding panel consists of a single skin of GRC attached to a prefabricated frame, usually metal, by means of L shaped flexible anchors (termed flex anchors) and support anchors (known as gravity anchors). Regular spacing of the flex anchors ensures that the effects of wind loading are evenly distributed over large areas of the panels. The flex anchors are for lateral support to the GRC facing whilst allowing some degree of rotation and shrinkage/moisture movement of the GRC. The gravity anchors are positioned along the bottom of the panels and support the self weight of the GRC.

Consideration needs to be paid to the material of the frame to avoid risk of corrosion and accordingly stainless steel or suitably treated and protected mild steel are used. This selection may depend on local building regulations.

The wall construction is typically completed by an inner skin of gypsum plasterboard and the space between the outer and inner skins filled with insulating material such as rockwool to give thermal insulation and good fire resistance. Figure 3.5 shows a typical arrangement of a stud frame for a rectangular GRC cladding panel.

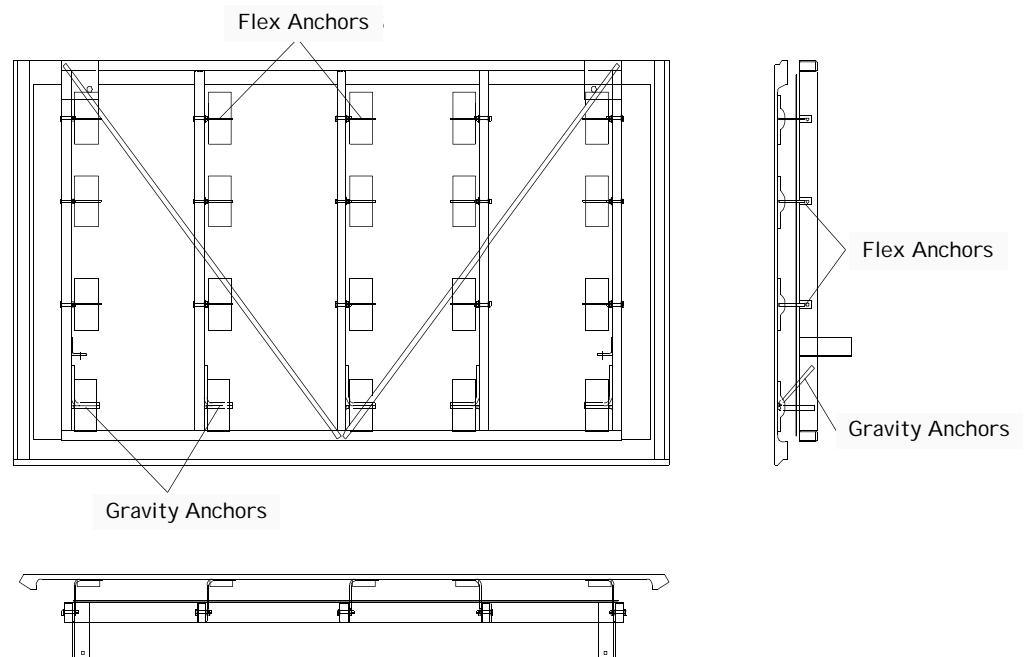

Figure 3.5 - Typical Arrangement of GRC Stud Frame



Figure 3.6 - Stud Frame fabricated from Rectangular Hollow Sections

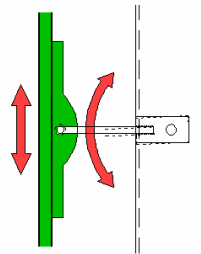

Figure 3.7 - Typical Flex Anchor showing Degrees of Freedom

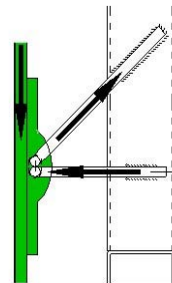

Figure 3.8 - Typical Gravity Anchor showing Load Paths

Figures 3.6 to 3.8 indicate how unbonded flex anchors and gravity anchors are intended to perform. Note how they all point to the centre of the panel to alleviate adverse shrinkage stresses.



**Figure 3.9 -
GRC stud frame construction
used for Globe-shaped
Architectural Feature**

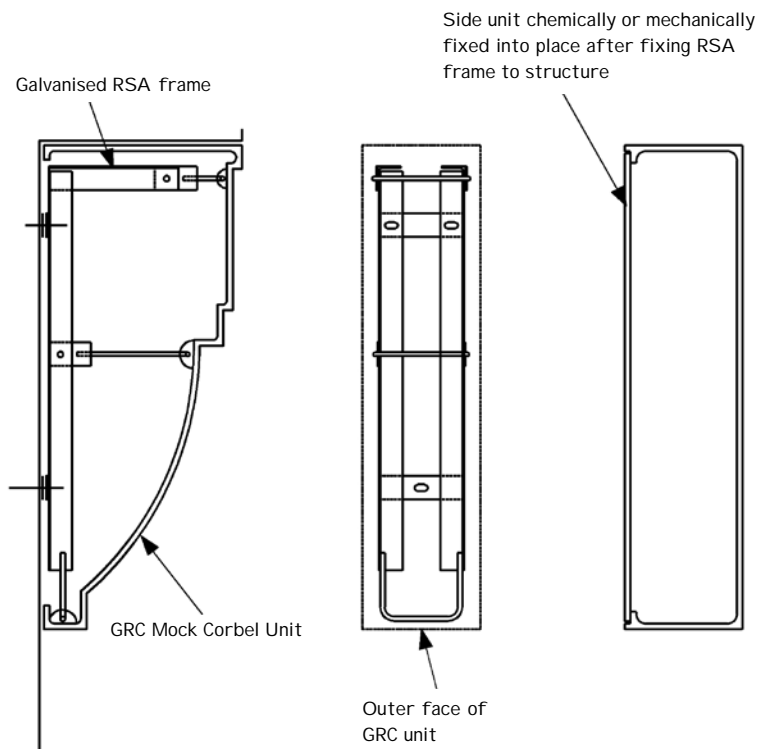

Figure 3.10 - Small Scale Stud Frame used for Mock Corbel



Figure 3.11 - Stud Frame Panels with Exposed Aggregate Finish



Figure 3.12 - Curved Stud Frame Panels for Portico Construction

Figure 3.13 -
Stud Frame Construction
Car Showroom, Oman



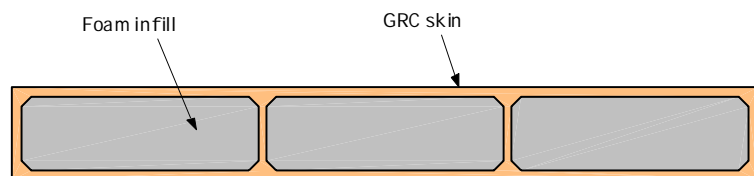

Figure 3.14 - Large Stud Frame Panel, USA

Whilst each method of stiffening has advantages, the use of the steel stud frame is often the most economical and preferred method for stiffening panels. In addition, the stud frame provides a support for attaching additional elements making up the complete wall construction (eg insulation, gypsum board and the window frame). Furthermore, this system also provides a cavity for electrical, mechanical and telephone conduits. Figures 3.9 to 3.14 illustrate several different applications for stud frame construction.

3.3 Sandwich Panel Construction

Sandwich panels are constructed with two outer skins of GRC separated by a lightweight insulating core. The two GRC skins are normally connected around the edges of the panels by a GRC edge return, and therefore the GRC completely encapsulates the lightweight core. This is termed 'box-type' sandwich construction. Both the front and back skins of GRC are typically between 10 to 15 mm thick (Figure 3.15).



Box-type Sandwich Construction

Figure 3.15

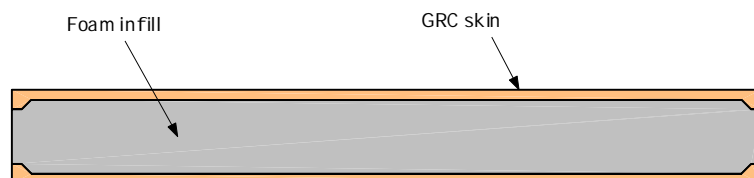

Bonded Sandwich Construction

Figure 3.16

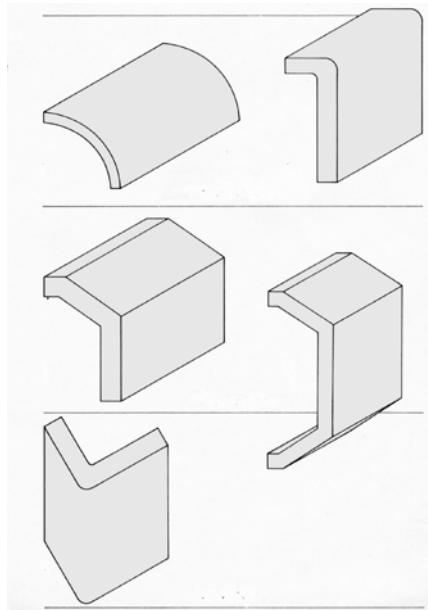

Figure 3.17 - Sandwich Panel Construction, Spain

The core material may be very light-weight with excellent insulation properties such as expanded polystyrene, polyurethane or isocyanurate foam, or somewhat heavier, as with polystyrene bead aggregate concrete which gives excellent fire performance.

Much less common is the 'bonded' sandwich construction shown in Figure 3.16. Here, the foam infill is much stiffer and becomes a structural element in that it is required to transmit shear stresses between the external skins

Sandwich construction is very efficient in load capacity and stiffness, as the GRC is positioned in the regions of maximum stress (in the tensile and compressive faces), Sandwich construction is useful in specific circumstances but it is not widely used in cladding panel construction. There is a potential for differential thermal and moisture movement between the outer and inner faces of a sandwich panel which can give rise to bowing, or high stresses if freedom of movement is not allowed by the shape and the panel fixing. Figure 3.17 illustrates an impressive project that used sandwich panel construction for the cladding.



Whilst some of the sandwich panels shown in Figure 3.17 are gently curved, it is advisable to only manufacture flat sandwich panels thereby avoiding problems associated with temperature gradients, moisture movements and shrinkage stresses. Figure 3.18 shows the shapes of panels that should not be used in sandwich construction.

It is recommended that flat sandwich panels should not have an area greater than 6.5 m² eg 3.6m x 1.8m.

Figure 3.18

4

FIXING SYSTEMS

A major part of the design process is to decide how and to what a GRC product is to be fixed.

4.1 Fixing Constraints

The main function of the fixing system is to secure the GRC component to the structure for the life of the component/structure. At the same time it must allow for thermal and moisture movement of the component and any differential movement between the structure and the component.

Fixing Systems must also:

- Provide sufficient adjustment to accommodate normal construction inaccuracies in combination with the anticipated movements.
- Maintain integrity of support and restraint under all conditions of exposure by minimising local concentrations of stress in the GRC
- Ensure that forces transmitted through the fixings are distributed over as wide an area of GRC as possible.
- Utilise the full strength properties of the GRC by providing supports at the base of the panels and lateral restraints at both the top and bottom of panels.

Panel fixing points should not be used for lifting and/or handling. Additional lifting points should be provided.

The decision on how to fix a GRC component is a fundamental part of the design process and should be taken as soon as possible, normally during the tender stage.

The decision on how to fix a GRC component is a fundamental part of the design process and should be taken as soon as possible normally during the tender stage. The choice of which system to use is often dictated by imposed constraints particularly if the structure is existing. Ideally, the design of the GRC component and its fixing system should proceed in parallel with the structural design.

Common fixing systems are described in the following sections.

4.2 Encapsulated Fixings - Fixings contained within a block of GRC.

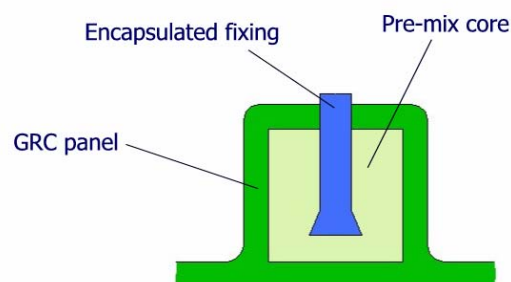

Figure 4.1

Encapsulated fixings generally consist of internally threaded tubes with some form of anchorage at the encapsulated end (cone shaped end or cross pin). Figure 4.1 shows the cone shaped end version. These fixings are encapsulated in a solid block of GRC with a length and width 10/15 times the bolt diameter. The minimum edge distance should be 8/10 times the bolt diameter. M8 to M16 are the most common sockets used with the choice dependent on the panel size.

It can be difficult to spray and compact the GRC around the socket and it is preferable to use premix placed and compacted by hand. The socket should be located by a jig to ensure accuracy of position and the encapsulation should take place as soon as possible after spraying. 5mm of the socket should protrude from the top of the GRC as this will help to prevent over stressing during subsequent fixing.

This is a very versatile method of fixing allowing a wide range of brackets plates or cramps to be bolted to the GRC panel and to the structure. There are, however, some disadvantages. The large blocks of GRC can add significantly to the weight of the panel and in some instances the outline of the block can be seen on the face of the panel, a phenomenon known as 'ghosting'.

4.3 Bonded fixings - Fixings attached to the GRC face by bonding pads.

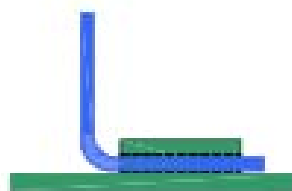

Figure 4.2 - Flex Anchor Fixing

The most common fixings of this type are the flex and gravity anchors used in the stud frame system but can also include brackets, bent plates and threaded connections. The fixing is suspended slightly above the face skin of freshly sprayed GRC and is attached using a bonding pad of GRC, which is normally premixed and placed by hand. The size and thickness of the bonding pad will vary depending upon the fixing but for 6 - 8mm diameter flex anchors the thickness should not be less than 12mm and the bonding pad size a minimum of 1500 mm². The bonding pad should be clear of the bend in the flex anchor, as shown in Figure 4.2, to avoid restricting the movement of the GRC. The time between the final roller compaction of the GRC skin and the application of the bonding pads must be kept to a minimum to ensure monolithic bonding and eliminate the possibility of subsequent de-bonding. If the flex anchor or bracket is allowed to press into the face skin of GRC ghosting, as previously described, can occur. The design pull out loads for embedded fixings should be proved by load tests and flex anchor pull of tests should be a part of regular QC testing.

The design pull out loads for embedded fixings should be proved by load tests and flex anchor pull of tests should be a part of regular QC testing.

4.4 Face fixings - Fixings secured through the face of the panel.

When access to the back of the component is restricted it can be necessary to face-fix the panels. A typical face fixing is illustrated below. The cast in washer is used to spread the load and the neoprene pad and oversized hole (in relation to the bolt diameter) give allowance for movement.

It is much easier to hide the fixing if the GRC cover piece is part of some surface feature.

The cover piece of GRC can be a tight fit and glued in place after final tightening of the bolt. It is, however, always difficult to hide the fixing hole, particularly if the component is not subsequently painted (Figure 4.3).

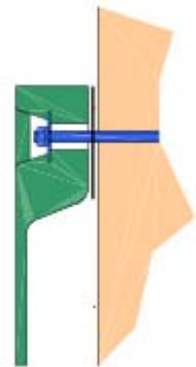

Figure 4.3 - Example of Face Fixing

4.5 Hidden Fixings - when access is restricted

When face fixing is unacceptable and access to the rear of the panel is restricted, it is necessary to use a slot and dowel type system (Figure 4.4).

The bottom edge of the GRC panel or a corbel within the panel is supported on a seating cleat or bracket. Lateral restraint is provided by a dowel or vertical plate attached to the cleat or bracket, which locates into an oversized hole or slot in the GRC panel. Vertical tolerance is achieved by the use of horseshoe shims and lateral tolerance by shimming between the bracket and the structure. There is some sideways tolerance by using oversized holes and elongated slots. The top restraint fixings are much simpler as the panel above can hide these.

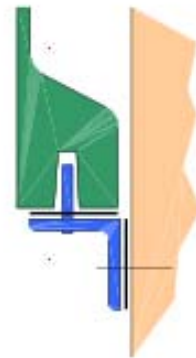

Figure 4.4 - Example of Hidden Fixing

4.6 Secondary Fixings.

As well as fixings to secure the GRC panel, fixings are also needed to attach components to the GRC panel. Typical examples being windows, flashings and rainwater drain pipes (Figure 4.5). Plastic or hardwood blocks can be encapsulated into the GRC and a screw connection made to attach the component. Care must be taken to ensure that the secondary fixing does not restrict the movement allowed for in the primary fixing system.

Care must be taken to ensure that the secondary fixing does not restrict the movement allowed for in the primary fixing system.

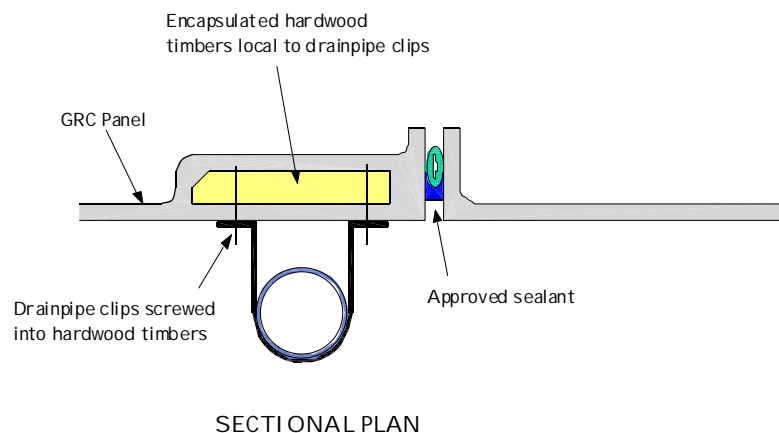

Figure 4.5 - Example of Secondary Fixing

4.7 Materials for Fixings.

For a more detailed consideration of fixing systems reference should be made to: 'Guide to Fixings for Glass Fibre Reinforced Cement Cladding' published by the GRCA

The choice of the correct materials for fixings is very important.

Brackets, plates, bolts, nuts, washers and cast-in items, sockets etc. are generally made of steel. The choice of which grade of steel should be made after consideration of local codes and regulations, clients requirements, environmental conditions, functional life of the structure and the possibility for inspection and maintenance. Economic considerations initially appear to favour cheaper materials but when total life costing is considered the benefits of a long life with zero maintenance and repair requirements can more than compensate for initial higher material costs.

Spacers and packers should be made from durable non-compressible material, plastic, GRC and stainless steel being widely used. Neoprene washers and packers are used to allow movement.

5.1 Principles of Design

GRC is not required to fulfil primary structural functions.

Loads must be estimated and combined to produce the most unfavourable conditions for design purposes.

GRC is mainly used to manufacture architectural and industrial products that are not required to fulfil primary structural functions. These products should still be carefully designed to ensure that they do not become unfit for use during their specified design life. The possible adverse effects of demoulding, handling, transporting and fixing should be taken into account. Stresses induced by shrinkage/thermal movements, dead loads and imposed loads must be calculated and combined to produce the most unfavourable conditions for design purposes.

The design should also consider likely variations in the thickness of the GRC, differences in bending behaviour between test coupons and the full size section as well as the mode of collapse and consequences of failure. It is logical to adopt a limit state design approach so that each of these effects can be associated with a partial factor of safety. Clearly, the designer should exercise sound and reasonable judgement in determining the values of the partial factors to be used in design. This approach also allows sensitivity analyses to be carried out using different values of the partial factors, thereby giving more control over the design than hitherto using the 'allowable stress' approach. Limit state design uses statistical techniques to determine the design loads and design strength from the corresponding characteristic values to account for likely variations in these design parameters during the design life of the GRC product.

Variations in both loading and material strength can be modelled by the distribution given by the Gauss function, commonly known as the *normal* distribution. This distribution is shown in Fig 5.1 where frequency density is plotted against the value of observation.

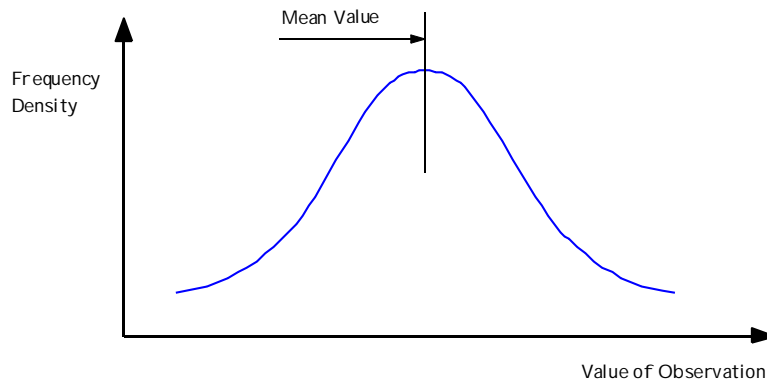

Figure 5.1

The estimated standard deviation (σ), ie the root mean square deviation, based on the sample mean (\bar{x}) of taking n samples or observations is given by

$$\sigma = \left[\sum (x_i - \bar{x})^2 / (n - 1) \right]^{0.5} \dots (5.1)$$

the summation being carried out with values of $i = 1$ to n .

In practice, a probability limit of 0.05 is adopted for both loading and material strength implying a variation of 1.64σ from the mean. Hence, the relationship between design load (F_d) and characteristic load (F_k) is as shown in Figure 5.2

$$\text{ie Design load } F_d = \gamma_f \cdot F_k \dots (5.2)$$

where γ_f is a partial factor of safety.

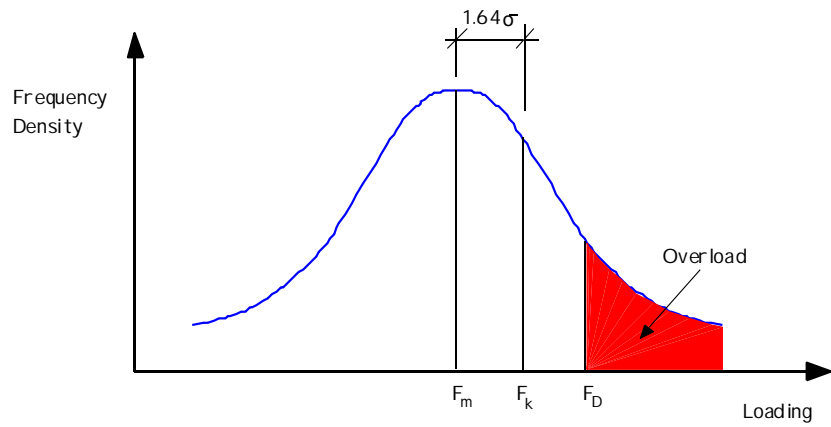

Figure 5.2

Similarly, the relationship between design strength (f_d) and characteristic strength (f_k) is given by

$$f_d = f_k / \gamma_m \quad \dots(5.3)$$

where γ_m is a partial factor of safety as represented in Figure 5.3.

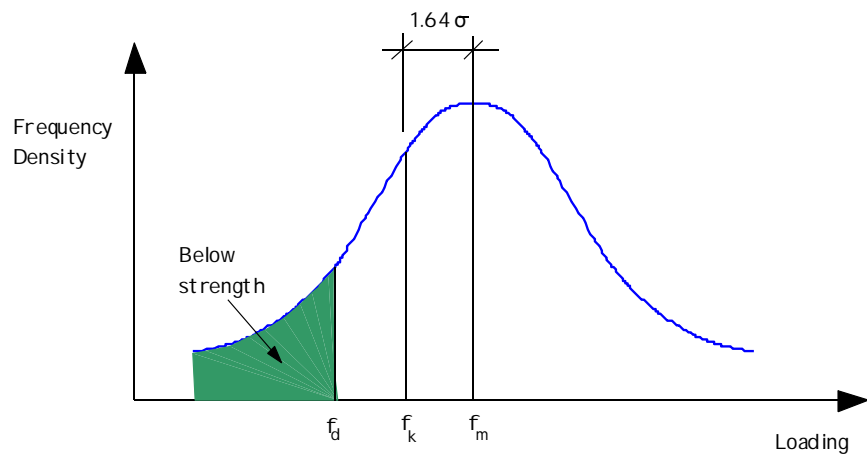

Figure 5.3

5.2 Partial Factors of Safety

The designer must check compliance with the limit states of collapse and serviceability.

When using limit state theory to design GRC elements, the designer must check compliance with the limit states of collapse and serviceability. In other words, the GRC element must not be allowed to collapse or become unserviceable during its design life. The partial factors of safety will be different for each limit state as described below.

5.3 Ultimate Limit State

Compliance with the ultimate limit state of collapse (ULS) is checked by

- a) factoring up the characteristic load (F_k) to obtain the ultimate design load (F_d)
 - b) factoring down the characteristic strength of the GRC (f_k) to obtain the ultimate design strength
- and
- (c) analysing the behaviour of the GRC element using these factored values.

We have, therefore, from Eqn (5.2)

$$\text{Ultimate design load} \quad F_d = \gamma_f \cdot F_k$$

where F_k = characteristic load

Partial factor of safety γ_f is given by

$$\gamma_f = \gamma'_f \cdot \gamma_{iv} \cdot \gamma_b \cdot \gamma_c \quad \dots (5.4)$$

where

γ'_f = load factor given in Table 5.1 below (values extracted from Table 2.1 of BS 8110)

Table 5.1 - Suggested values of γ'_f for the ULS

Load Combination	Load Type					
	Dead (DL)		Imposed (LL)		Earth & Water Pressure	Wind
	Adverse	Beneficial	Adverse	Beneficial		
DL + LL (and earth & water pressure)	1.4	1.0	1.6	0	1.4	-
DL + Wind (and earth & water pressure)	1.4	1.0	-	-	1.4	1.4
DL + LL + Wind (and earth & water pressure)	1.2	1.2	1.2	1.2	1.2	1.2

γ_{tv} = factor to account for variations in thickness of GRC

γ_b = factor to allow for differences in bending behaviour between test coupon and full size section

γ_c = factor to account for mode of collapse and consequences of failure

Suggested values of γ_{tv} and γ_b are given in Tables 5.2 and 5.3 respectively.

Table 5.2 - Typical Values of γ_{tv} for the ULS (with good quality control)

Process	Single Skin		Sandwich Construction	
	Plain	Moulded	Plain	Moulded
Hand Spray †	1.05	1.1	1.1	1.2
Machine Spray ¶	1.0	1.05	1.05	1.1

† 10mm minimum thickness

¶ 6mm minimum thickness

Table 5.3 - Typical Values of γ_b for the ULS (with good quality control)

Overall Thickness (mm)							
Single Skin				Sandwich Construction †			
6 - 10	12 - 16	20	40	60	100	200	300
1.0	1.05	1.08	1.15	1.20	1.25	1.37	1.50

† For open sandwich or box sections take $\gamma_b = 1.5$ irrespective of depth

Normally, γ_c is taken as 1.0 but values in the range 1.0 to 1.5 may be appropriate for certain applications

Eqn (5.3) gives the design strength (f_d) as

$$f_d = f_k / \gamma_m \quad \dots (5.5)$$

where f_k = characteristic strength and γ_m = partial factor of safety.

Typical values for γ_m for the ultimate limit state are given in Table 5.4 below.

Table 5.4 - Typical Values of γ_m for the Ultimate Limit State

Mix	Exposure (Long term)		Handling 28 to 90 days (Short term)
	Natural weather - external	As stored - internal	
Standard GRC with sand/cmt ratio of 1:1	3 to 3.5	2.5 to 3	1.7 to 2.2

5.4 Serviceability Limit State

Compliance with the serviceability limit state (SLS) is checked by

- determining the characteristic load F_k (= service design load F_{sd})
ie load factor $\gamma_f = 1$
- factoring down the characteristic strength of the GRC (f_k) by a global factor of $\gamma_m = 1.8$ for long term loading or $\gamma_m = 1.4$ for short term loading to obtain the serviceability design strength
- analysing the behaviour of the GRC element using these values
- check the serviceability limit state of deflection using F_k and $\gamma_f = 1$ and an appropriate value of Young's Modulus (E). An estimate of the deflection due to thermal and/or moisture bowing should be added to the calculation elastic deflection (y_e) to obtain a total value for deflections. Long-term deflections should be limited to span/350 whilst deflections under short-term test loads should be limited to span/625. The Highway Agency in UK limit deflections to span/300 for wet concrete only.

5.5 Shrinkage & Thermal Stresses

Restrained shrinkage and thermal movements can induce very high stresses into the GRC product.

It should be noted that restrained shrinkage and thermal movements can induce very high stresses into the GRC product. GRC has a relatively high shrinkage rate of about 0.15% for complete drying of a 'standard' mix. The assessment of appropriate values for induced shrinkage stresses should carefully consider the environment in which the GRC product will be used. Dry conditions will generally cause higher shrinkage stresses than wet conditions. A surface coating may reduce the adverse effects of wetting and drying.

The factors influencing stresses induced by thermal movements are the coefficient of expansion, the modulus of elasticity, strains resulting from a temperature differential and the effects of creep/relaxation.

In terms of making simple but conservative allowances for shrinkage and thermal stresses, approximate values of shrinkage stress (σ_{ss}) and thermal stress (σ_{ts}) given in Tables 5.5 and 5.6 respectively may be used for design at the limit state of collapse and serviceability using the appropriate partial factors of safety.

Table 5.5 - Suggested Values of Shrinkage Stress (σ_{ss}) in N/mm²

Full Restraint	Short-Term	Full-Term
Internal	1.3 to 1.8	0.7 to 0.9
External	1.0 to 1.5	0.5 to 0.8

Table 5.6 - Suggested Values of Thermal Stress (σ_{ts}) in N/mm²

Condition	Tension Face	Temperature Gradient (deg C)	σ_{ts}
Winter	Damp	5	0.4 to 0.8
		10	0.9 to 1.7
		15	1.4 to 2.5
Summer	Dry	5	0.2 to 0.5
		10	0.4 to 0.9
		15	0.6 to 1.3
		20	0.8 to 1.8

5.6 Bending & Shear

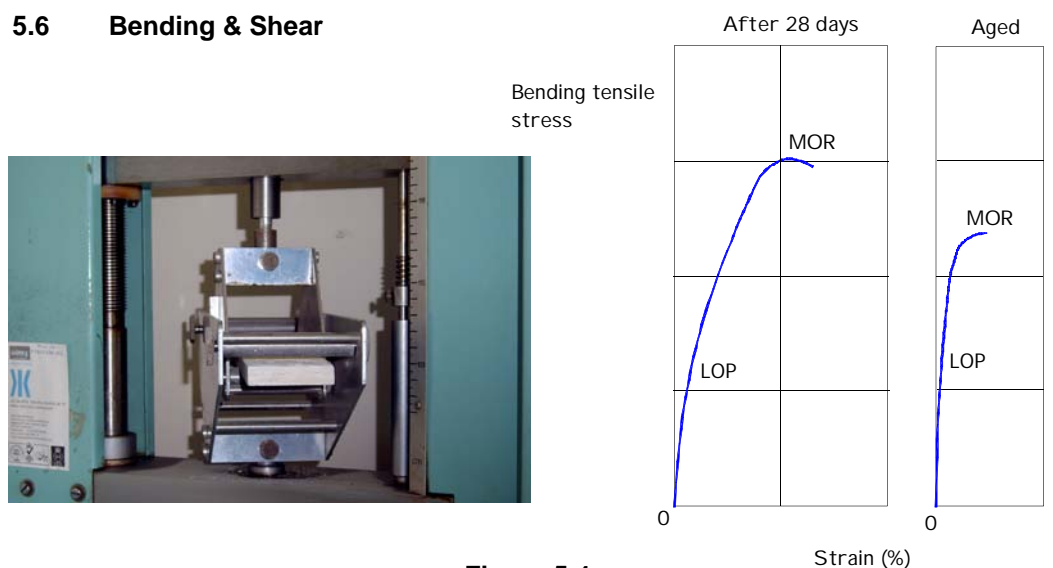

Figure 5.4

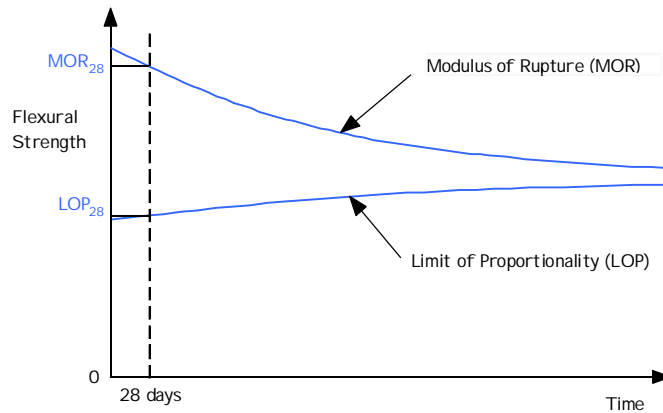

Figure 5.5

Flexural tests on GRC coupons are carried out using a four point bending test (see Section 2.2). Typical plots of stress against strains are shown in Figure 5.4. The limit of proportionality (LOP) marks the end of the linear variation between stress and strain. Thereafter, the strain increases faster than the stress terminating in failure at the so-called modulus of rupture (MOR). Early LOP and MOR strengths are both affected primarily by glass fibre content, fibre length/orientation, polymer content and composite density. As GRC ages, the LOP may increase slightly in value whilst the MOR decreases. Over a long period of time, the two values converge almost to the same value as indicated in Figure 5.5.

Bending is usually the most critical and predominant loading condition to be considered in the design of GRC elements.

Bending is usually the most critical and predominant loading condition to be considered in the design of GRC elements. In designing GRC elements subjected purely to bending and shear, the characteristic strength at the ultimate limit state is taken as the MOR at 28 days (MOR_{28}). The characteristic strength at the serviceability limit state is taken as the LOP at 28 days (LOP_{28}). The worked examples that follow demonstrate the use of these characteristic strengths in design.

Shear seldom controls the design of GRC elements. The three basic types of shear are illustrated in Fig 5.6. Principle tensile stresses resulting from the action of shear should be limited to $0.4 \times$ ultimate flexural strength of the GRC. Interlaminar shear is usually the most critical of all the shear conditions. A characteristic value of 3.5 N/mm^2 is a reasonable design value to take for well made, properly compacted and cured 'standard' GRC. A value of $\gamma_m = 1.7$ is considered to be representative, hence the ultimate interlaminar shear strength = $3.5/1.7 = 2 \text{ N/mm}^2$ say. Typical value of f_k and γ_m to be used for in-plane shear design of 'standard' GRC components are $f_k = 9 \text{ N/mm}^2$ and $\gamma_m = 2$, hence ultimate in-plane design shear strength = $9/2 = 4.5 \text{ N/mm}^2$.

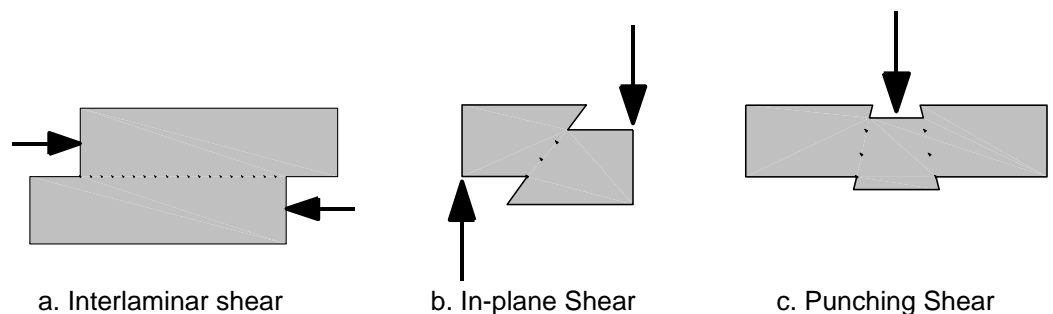
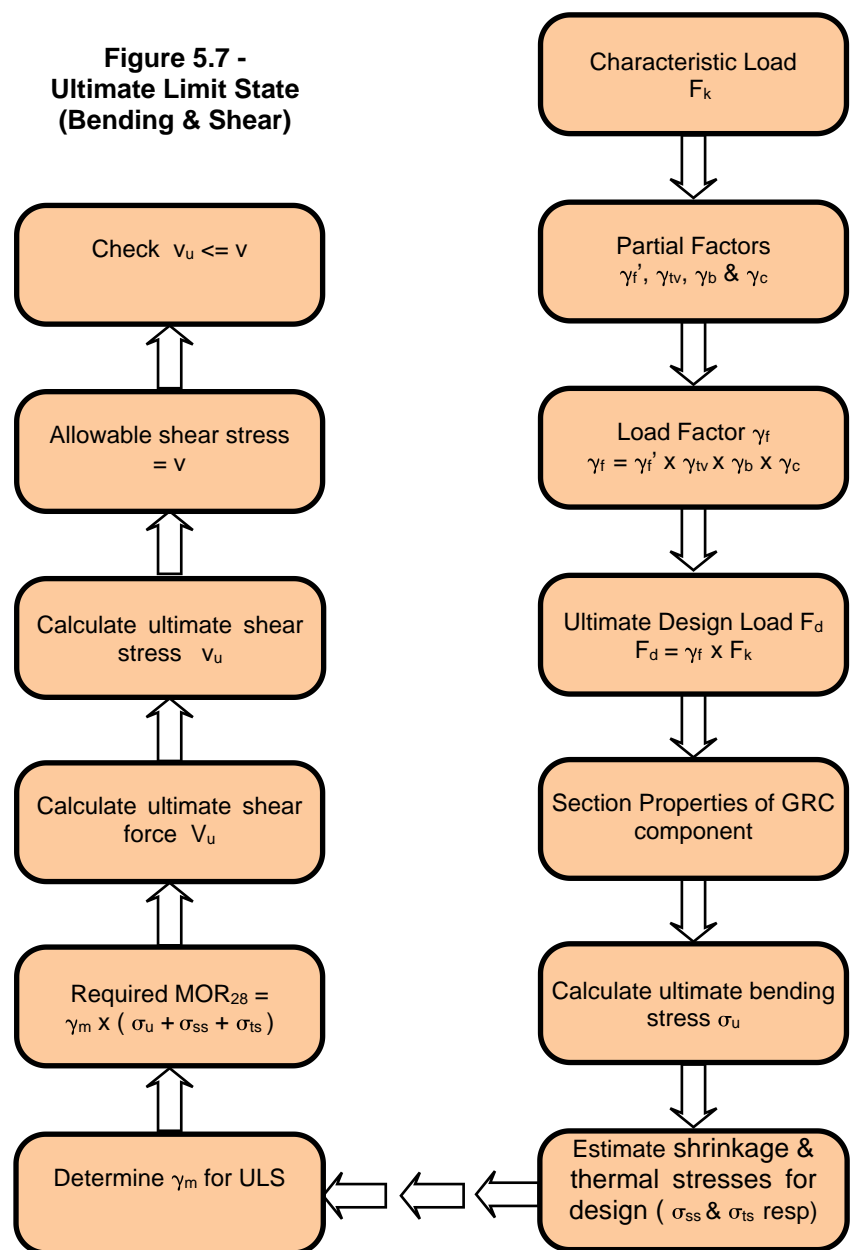

Figure 5.6

Ultimate punching shear values vary between 20 N/mm² and 45 N/mm² for non-dewatered material. Ageing has little effect. Due to the significant influence of test methods, it is proposed to conservatively base punching shear calculations on the same value as that used for in-plane shear.

The design check for compliance with the ULS and SLS for members subjected to bending and shear is shown in the form of flowcharts in Figures 5.7 and 5.8 respectively for easy reference.



**Figure 5.8 -
Serviceability Limit State
(Bending & Shear)**

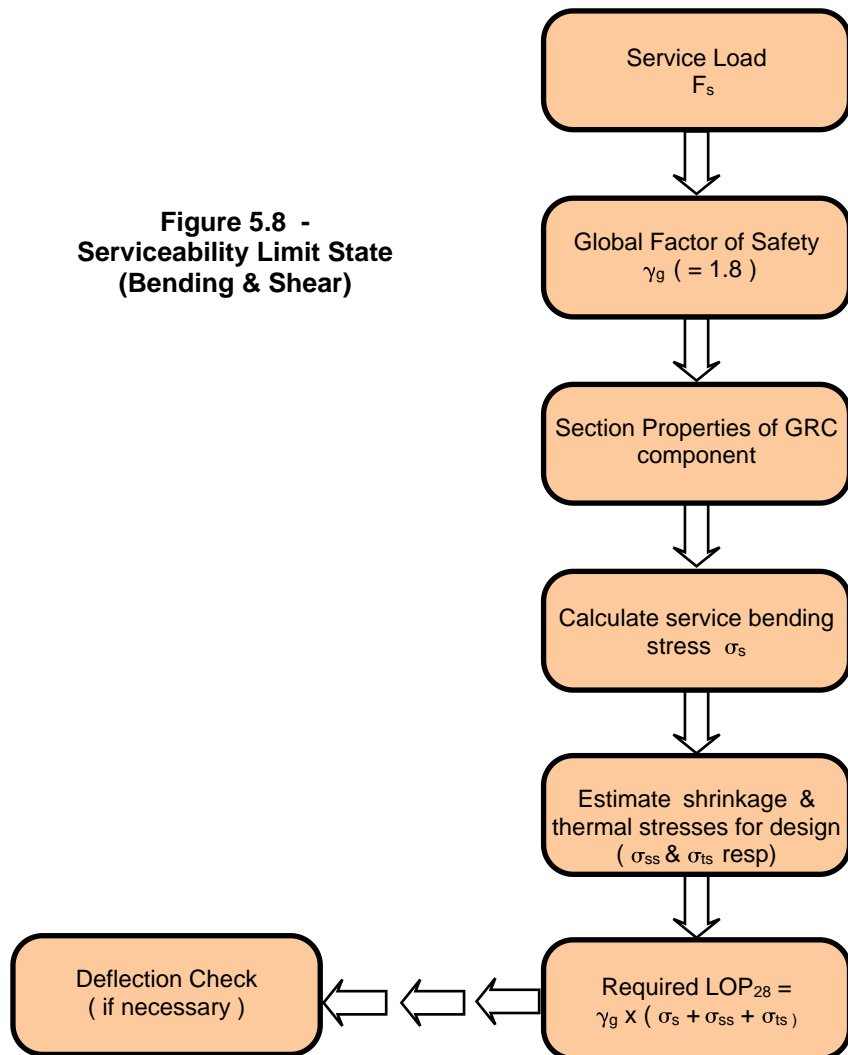

The limit state design process for members subjected to bending & shear can be briefly summarised as follows:

Summary - Bending & Shear

Ultimate Limit State (ULS)

Ultimate bending stress = σ_{ub} , shrinkage stress = σ_{ss} and thermal Stress = σ_{ts}

hence, $MOR_{28} \geq \gamma_m (\sigma_{ub} + \sigma_{ss} + \sigma_{ts})$

Ultimate interlaminar shear stress = v_u , so $\gamma_m \times v_u \leq 0.4 \times LOP_{28}$

Serviceability Limit State (SLS)

Service bending stress = σ_{sb} , hence $LOP_{28} \geq \gamma_g (\sigma_{sb} + \sigma_{ss} + \sigma_{ts})$

$\gamma_g = 1.8$ for long term loading

$\gamma_g = 1.4$ for short term loading

5.7 Direct Tension

Logically, the ultimate limit state of direct tension is related to the characteristic ultimate tensile stress at 28 days. The serviceability check is correspondingly related to the characteristic bend over point stress (BOP) at 28 days.

Hence, the ultimate direct design strength = UTS_{28} / γ_m ... (5.5)

and

Serviceability direct tensile design = $BOP_{28} / 1.8$... (5.6)

The UTS_{28} is usually limited to 40% of MOR_{28} whilst the BOP_{28} can be taken as $LOP_{28}/1.5$.

Design procedures for checking compliance with the ultimate and serviceability limit states follow much the same logic set out in Figures 5.7 and 5.8

5.8 Design Aids

Two very useful software packages are provided with this design manual to assist the designer in (a) calculating the section properties of complex cross-sections and (b) determining the type, size, number and disposition of stiffening ribs should these be required. Details of these design aids are as follows:

- a. **SectRib** - a shareware Windows program with an intuitive graphical user interface and easy entry of data for obtaining section properties of flat, ribbed panels, corrugated panels and any other general sections
- and
- b. **SectProp** - a shareware version of a program that runs inside AutoCAD (not AutoCAD LT) and produces more comprehensive output than the one provided in AutoCAD. It easily deals with circular, curved boundaries.

5.8.1 Sectrib

SectRib runs in the Windows environment and greatly simplifies input for flat, ribbed panels. There is no need to calculate and enter cartesian coordinates for the boundary nodes for ribbed panels because this is done automatically. It is an easy matter to edit/change data and numerous data checks ensure that invalid data cannot be entered. The comprehensive output is customisable with respect to Company logos. This software also allows rotation of the section in order to investigate different stress conditions.

A very useful feature of SectRib is the auto-calculation of the minimum projection of ribs to satisfy stress calculations. Clearly, the type and number of internal and external ribs must first be specified together with the required section modulus.

SectRib also includes a transformation utility for transforming a box rib panel section into a corrugated one, like those used for permanent formwork. The software also has a 'mirror' facility that expedites the input of data for symmetrical sections.

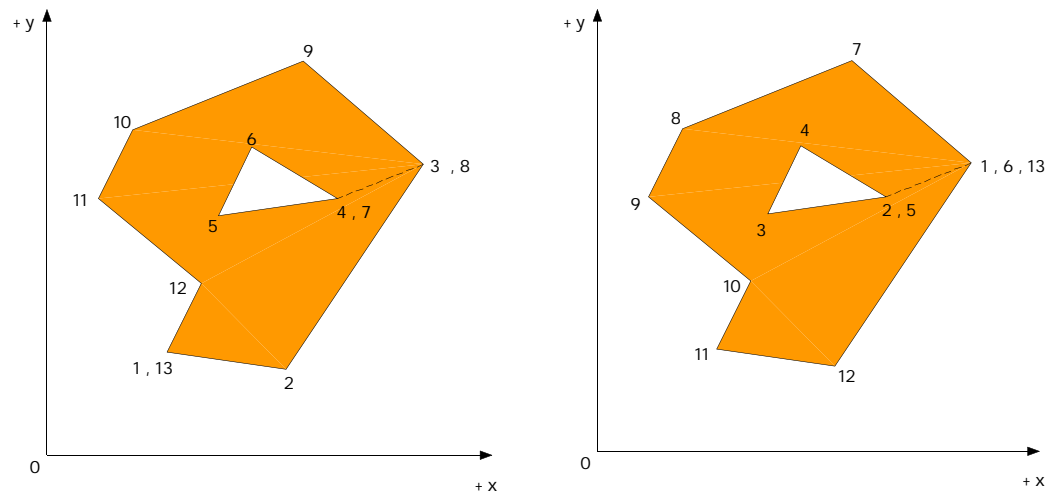
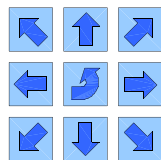

Figure 5.9

Whilst being intended for use in designing flat ribbed panels, SectRib can also be used to calculate the section properties of any irregular section bounded by straight lines, with or without internal boundaries.

Basically, both internal and external boundaries are defined by nodes joined by a series of straight lines. Nodes defining the outer boundary must be numbered in an anti-clockwise direction whilst the nodes of internal boundaries must be numbered in the opposite clockwise direction as indicated below. Both the numbering examples shown in Figure 5.9 are acceptable and will yield the same answers. In the case of general sections, SectRib requires the user to input POSITIVE values of x and y for each node, the first node being entered at least twice to effectively close the cross-section. The software comes with the usual load, save, print and help file facilities.



Entry of co-ordinate data is much easier if relative co-ordinates are entered using the 'relative co-ordinate' keypad shown opposite. All relative co-ordinates are entered as positive values as demonstrated in the simple example shown in Figure 5.10.

There is no need to enter the last co-ordinate to 'close' the section because the program does so automatically.

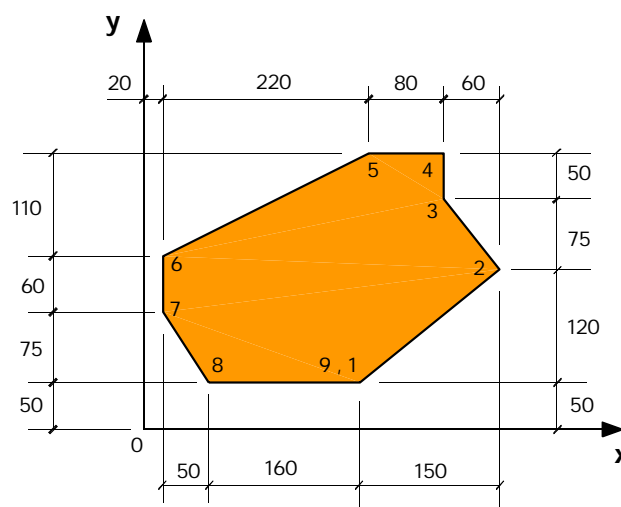

Co-ord No	'Key'	Values (mm)	
		x	y
1	-	230	50
2	↗	150	120
3	↖	60	75
4	↑	0	50
5	←	80	0
6	↙	220	110
7	↓	0	60
8	↘	50	75
9	→	160	0

Figure 5.10

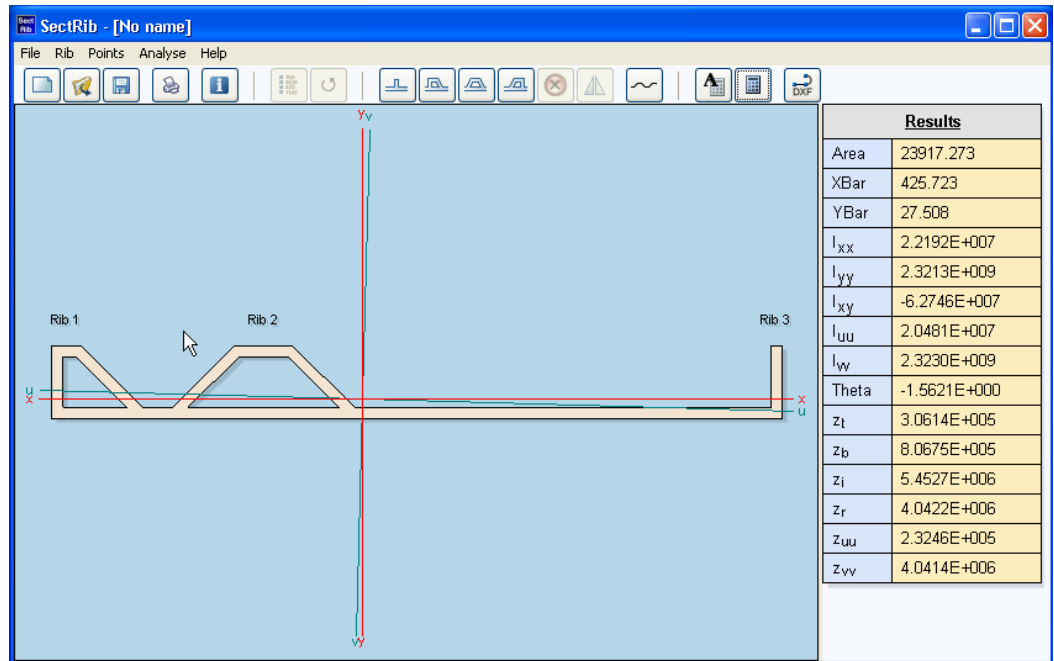

Figure 5.11

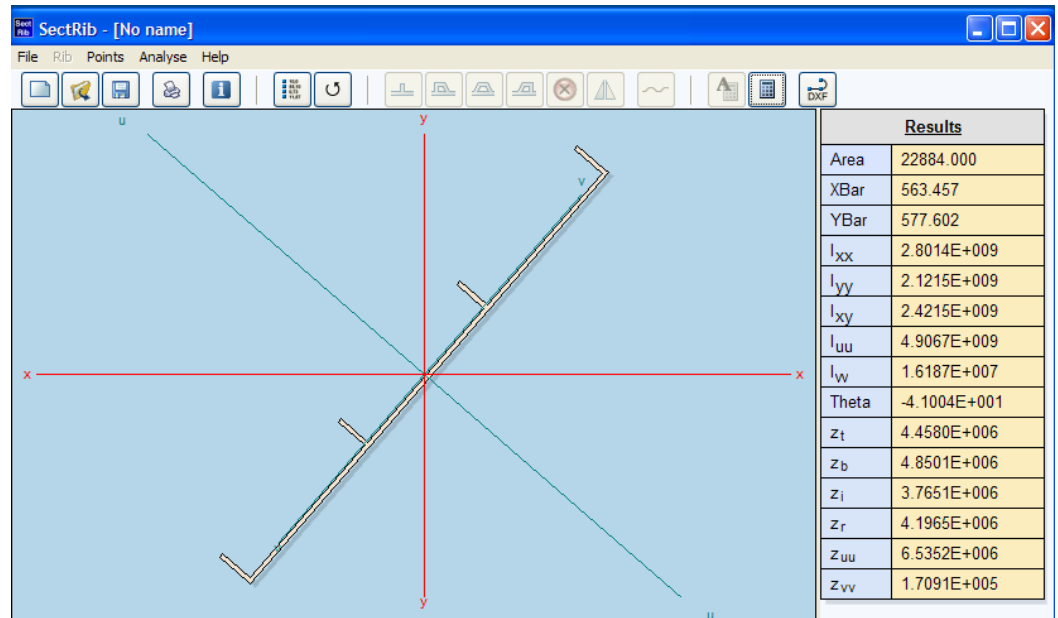

Figure 5.12

The software comes with the usual load, save, print and help file facilities. Screenshots of the software are shown in Figures 5.11 and 5.12.

The main features of this basic but very useful software can be summarised as follows:

- Intuitive graphical user interface (GUI) running in the Microsoft Windows environment for easy entry and editing of input data
- Numerous error checks to validate data
- AutoCalc button to determine the minimum projection of the ribs given all other necessary data
- Allows mixture of single and box type ribs
- Easy insertion / removal of ribs
- 'Corrugated' section feature to facilitate easy specification of sections for permanent formwork and corrugated roof sheeting
- 'Mirror' facility for symmetrical sections
- Outputs area, position of centroid, second moments of area and section moduli about orthogonal and principal axes
- Production of DXF files for use in detailing with AutoCAD or other compatible software
- Section properties of any irregular section, with or without internal boundaries, can be easily calculated.

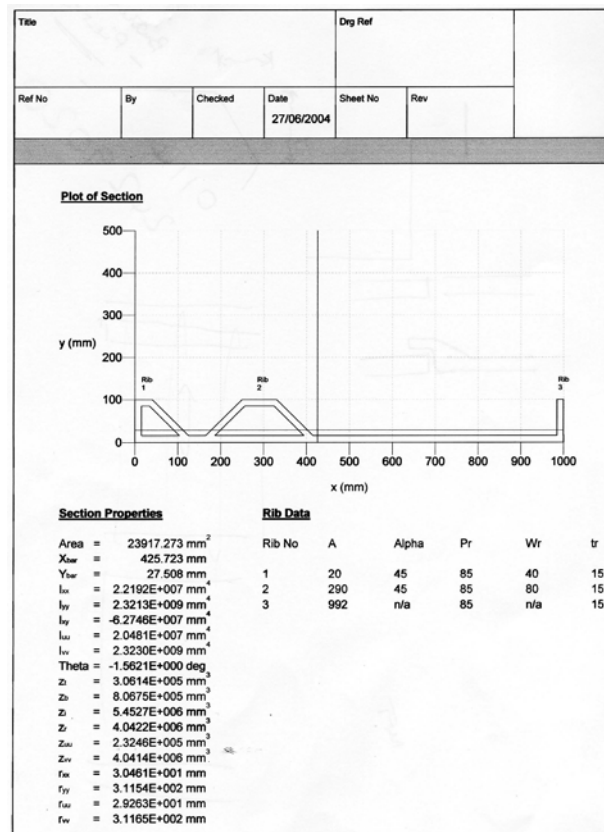

Figure 5.12 - shows a typical print-out from SectRib listing the required section

Figure 5.12 illustrates the logic of the program in the form of a flowchart. The program is supplied with an on-line help file.

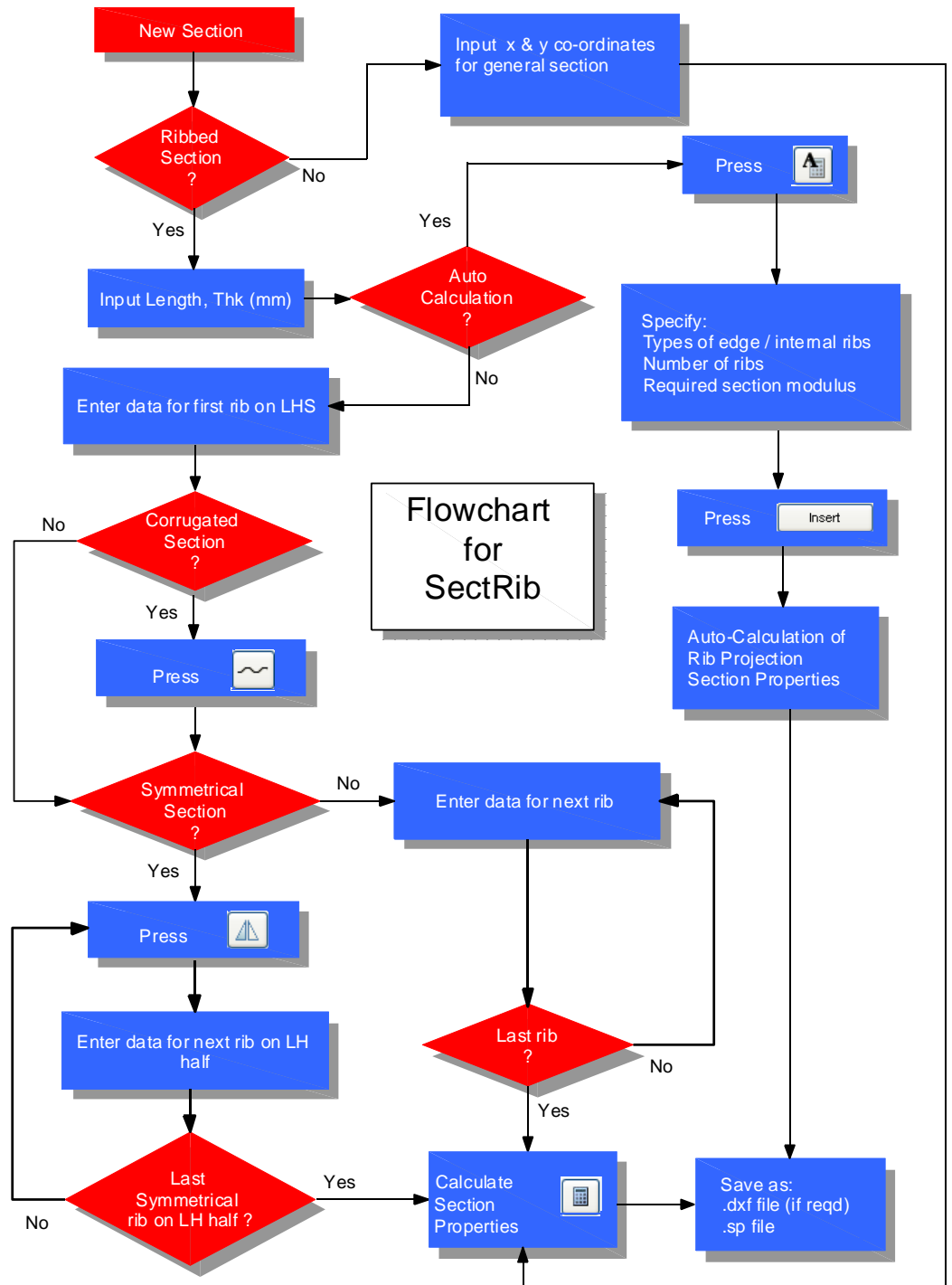

Figure 5.12

5.8.2 SectProp

SectProp is very easy to install and use. Once installed inside AutoCAD the software is activated by typing 'SECTPROP' on the Command line. Both external and internal boundaries must then be defined as polylines (not regions). A screenshot of the output is shown in Figure 5.13. Clearly, this package is easier to use than SectRib particularly when the section is bounded partly or fully by circular arcs.

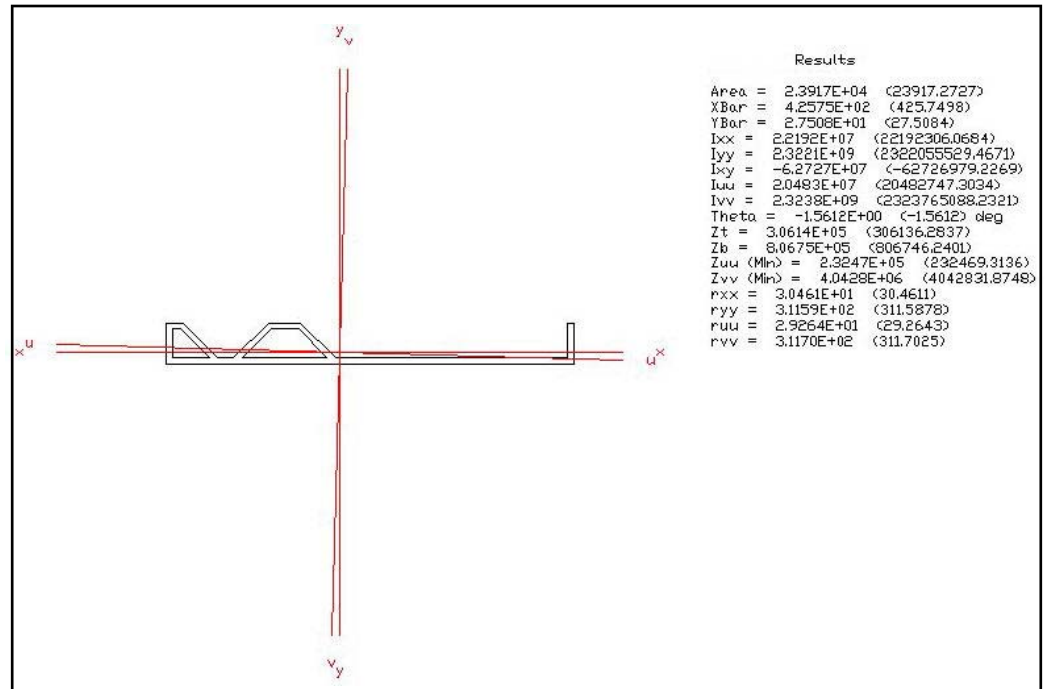

Figure 5.13

The main features of SectProp are as follows:

- Numerous error checks to validate data
- Complex cross-sections easily drawn in AutoCAD with external and internal boundaries specified as polylines
- Nodes do not require numbering - SectProp automatically does this to relieve user of difficulties and tedium of entering co-ordinates
- Easy editing of cross-sections using AutoCAD's powerful editing features
- Rotation of axes easily accomplished in SectProp using AutoCAD's rotation tool
- Results can be included in drawing alongside section under consideration
- Accuracy of calculation when boundaries contain circular arcs can be easily specified by user. Extremely high degrees of accuracy are possible.

SectRib and SectProp complement each other and offer the designer two very useful, time-saving tools. It is the intention of the GRCA International to refine these software packages further and develop others for the benefit of the end user. The GRCA website will post the latest versions of these two packages and announce others as and when they become available..

A shareware (evaluation version) of SectProp is provided on the CD and on the GRCA website <http://www.grca.org.uk>. Members of the GRCA will receive a substantial discount should they decide to purchase a copy of SectProp.

5.9 Future Developments

This Practical Design Guide will be reviewed and updated at regular intervals. It is a 'live' document that will develop with time.

The GRCA is committed to further testing of GRC elements, especially with the help of manufacturers and academic Institutions. Interpreted results of tests will be reported in revisions to this Guide as will the development of new software and CAD add-ons eg parametric utilities to improve the efficiency and accuracy of detailing GRC products, fixings and support systems.

Regular references should be made to the GRCA website <http://www.grca.org.uk> to update the content of your Design Guide.

Constructive feedback and 'wish lists' will be gratefully received and carefully considered.

Structural Engineers involved in the design of steel GRC stud frame systems will be please to learn of a very powerful, freeware structural engineering package from which they can benefit

Integrated Structural Software are pleased to announce that they will providing much of their "ROBOT Millennium" software free of charge in the future. Engineers in the UK, Ireland and North America may register for their "ROBOT Freeware" software via the internet on www.issrobot.co.uk.

Registration is a simple process after which ISS will send the user a password to use the software. ROBOT Freeware will be an "indefinite" licence and does not require any commitment from the user at any time towards ISS. Key features of ROBOT Freeware are:

2d frame, truss and grillage analysis of up to 3000 nodes

3d frame and truss analysis of up to 3000 nodes

Section libraries and section property calculator for any arbitrary section shape

Parameterised library structures (trusses, frames etc)

FE plate and shell analysis with auto meshing – up to 50 finite elements

Linear analysis and 1st mode dynamic analysis

In fact **ROBOT Freeware** will provide a solution for the engineer to carry out the vast majority of their everyday analysis work.

***FREEWARE structural
engineering package
available on the web -
extremely useful for
designing steel, GRC stud
frame projects***

6

LIMIT STATE DESIGN OF FIXINGS

6.1 Functions of Fixings

The main functions of fixings for GRC cladding panels are as follows:

- a. to secure the cladding panels to the building for the life of the panels and/or building.
- b. to allow translational and rotational movements to occur between individual panels and between the panel(s) and supporting structure whilst maintaining waterproofing at the joints.
- c. to provide sufficient adjustment to accommodate *normal* constructional inaccuracies in combination with the anticipated movements referred to in (b) above.
- d. to maintain integrity of support and restraint under all conditions of exposure (impact, vibration, wind, fire, etc) by minimising local concentrations of stress in the GRC.
- e. to ensure that forces transmitted through the fixings are distributed over as wide an area of GRC as possible.
- f. to utilise the full strength properties of the GRC by providing supports at the base of the panels and lateral restraints at both the top and bottom of the panels.

Properly designed lifting points are also required. Permanent fixings should not be used for lifting.

The movements in (b) above can be difficult to quantify. However, it should be possible to make conservative estimates of the magnitudes and directions of these movements for the purposes of designing the fixings and joint sealants.

6.2 Overview of Design Principles

In order to produce a safe, efficient and economic fixing system, it is necessary to understand the basic design principles and criteria.

The designer should first identify any constraints which might be imposed by conditions on site. Such constraints, if any, may have a significant influence on the choice and detailed design of the fixings. Typical examples of these constraints are problems associated with access, conflict with fixings for other elements, excessive misalignments of support elements and conformance to a demanding programme of works.

GRC panels should not be 'over-fixed' to the structure as this will inhibit moisture and thermal movements and is likely to result in detrimental cracking of the panels. Fixings are usually provided at each of the four corner points of the panels.

The structural behaviour of the GRC panels under load should be carefully examined. It is advisable to avoid long horizontal panels (with span/depth ratio >4) as bending can cause distress of the GRC in the vicinity of the fixings due to rotational and/or translational movements.

Fixings should also be positioned so as to minimise any permanent stresses which might be induced into the panels. Forces transmitted through the fixings should be distributed over as wide an area of GRC as possible. Adequate bearing areas must also be provided for the GRC on the supports at the base of the panels to avoid distress to the GRC.

GRC panels should not be 'over-fixed' to the structure as this will inhibit moisture and thermal movements and is likely to result in detrimental cracking of the panels.

Important information about tolerances and inaccuracies which should be considered in the design of the fixings are given in BS 8110 for insitu concrete, BS 8297 for cladding and the National Steelwork Standard for steel frames. Adequate tolerances must be incorporated into the fixing system if it is to perform functions (b) and (c) listed in Section 6.1. Ideally, all fixings should be easily accessible for adjustment although this is not always possible.

It is important to remember that galvanised fixing components have a finite life which is directly proportional to the thickness of the zinc coating. As a general rule, stainless steel fixings should be used whenever possible because of their high resistance to corrosion. Stainless steel is an obvious choice of material for fixings which are unavoidably inaccessible (positioned out of sight).

As a general rule, stainless steel fixings should be used whenever possible because of their high resistance to

6.3 Types of Fixings

This design guide is only concerned with those fixings that are in direct contact with the GRC panel as opposed to those securing the panel to the supporting structure. The four types of commonly used direct fixings considered here are cast-in sockets, bonded fixings, dowels and face fixings (Figure 6.1).

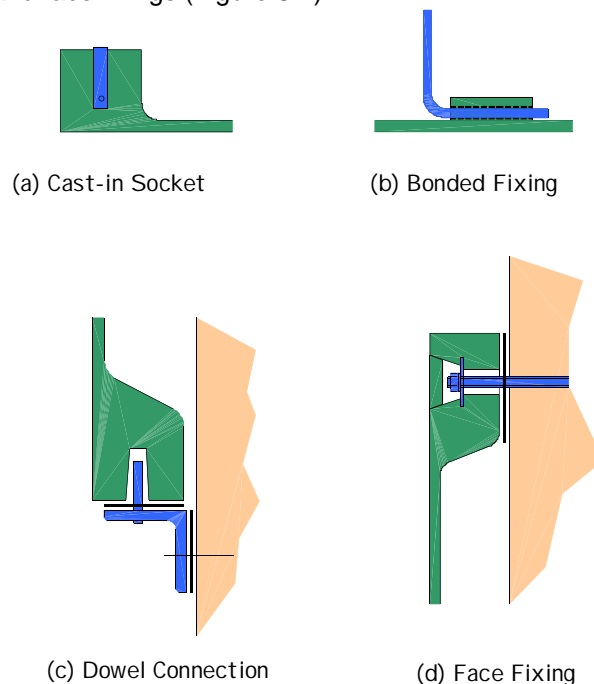

Figure 6.1

Failure mechanisms of all these types of fixings can be complex and so calculations are usually based on the results of representative ultimate load tests.

Failure of cast-in sockets is affected by edge distances, length of cast-in socket, type of anchorage (cross-pin, nut tapered end) and nature of loading (pure tension/compression, combined loading, eg tension and shear). It is very important that cast-in sockets are encapsulated in an adequate volume of GRC with 'good' fibre distribution around them. The ends of these sockets should be left slightly proud of the GRC to avoid the possible adverse effects of overtightening against the face of the GRC during fixing.

It is very important that cast-in sockets are encapsulated in an adequate volume of GRC with 'good' fibre distribution around them.

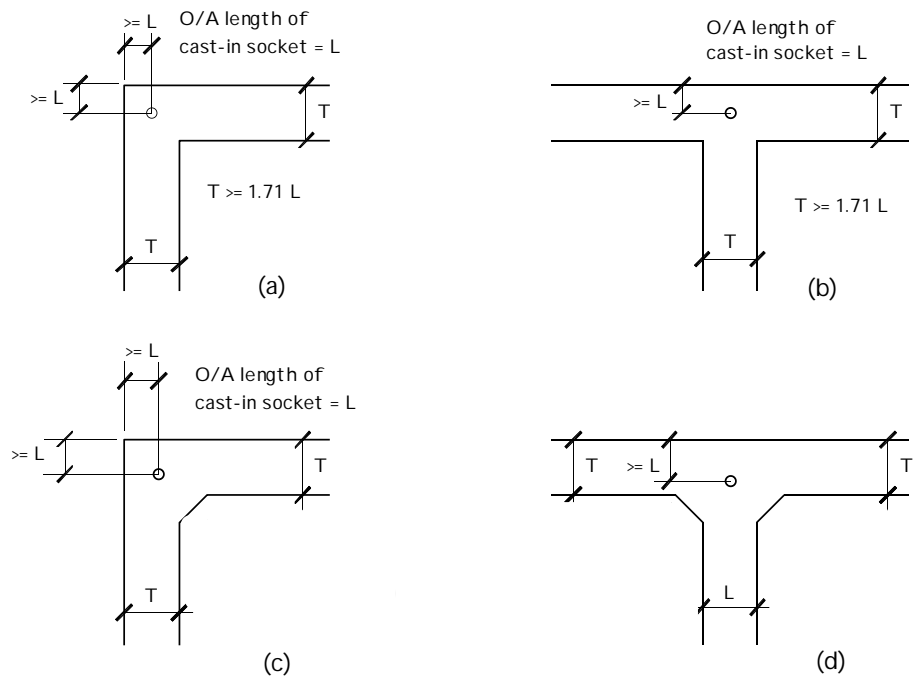
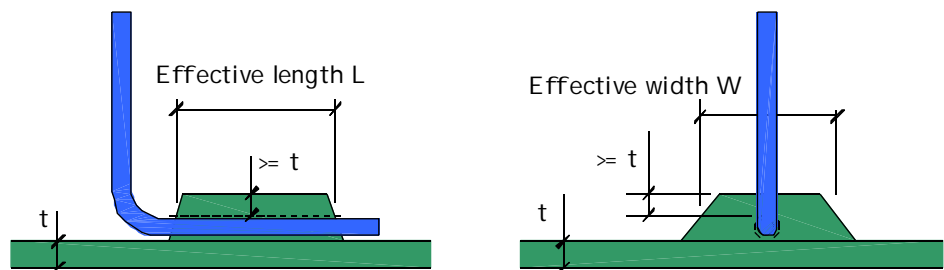

Figure 6.2

The actual performance and minimum edge distance of cast-in sockets will be specified by the manufacturer. However, as a general rule, the socket should not be placed any nearer to the edge of the GRC than the overall length of the socket as indicated in Figure 6.2. It should be noted that dimension T is the **minimum** width of the box rib. As far as stress concentrations in the GRC are concerned, it is good design practice to adopt the chamfered details shown in Figure 6.2 c and d. Bonding pads are usually deposited over the steel anchor bar or flat by hand and kneaded into the GRC backing. This is followed by final compaction using a serrated roller to ensure adequate bonding between bonding pad and backing. Figure 6.3 indicates the minimum sizes of bonding pads. The ultimate strengths of encapsulated fixings and bonding pads should be determined from representative tests to destruction.



$$W \times L \geq 16000 \text{ (mm units)} \quad \& \quad W > 12t$$

Figure 6.3

6.4 Ultimate Limit State of Fixings

When an encapsulated or bonded fixing to GRC fails it is likely to do so suddenly and without warning, albeit after a redistribution of load to one or more of the other fixings. It is proposed that for the purposes of conservatism and expediency, the following partial load factors are used for Grade 18 sprayed GRC in checking compliance with the ULS:

$$\gamma_{st} = 1.1, \quad \gamma_{tv} = 1.1 \quad \text{and} \quad \gamma_c = 2.30$$

A partial material factor of $\gamma_m = 2.20$ is considered to be adequate for taking account of any fibre discontinuities in the GRC.

See 'GRC and buildings' by
M W Fordyce & R G
Wodehouse published by
Butterworths in 1983.

6.5 Serviceability Limit State of Fixings

The main serviceability limit state to be satisfied by fixing assemblies is durability. This is threatened by cracking of the GRC close to the connection. GRC bonding pads should be sufficiently thick and extensive to ensure that fire regulations are met and that corrosion of the metallic elements is prevented. Basically, the following types of metals should be used : stainless steel, phosphor bronze, aluminium bronze and silicon aluminium bronze. Metallic elements of fixing assemblies should be kept dry and isolated to avoid electro-chemical attack.

6.6 Gravity Anchors in Stud Frame Construction

Gravity anchors are intrinsically more difficult to design than flex anchors because the failure mechanism of the bonding pad is due to a critical combination of vertical and horizontal loading (Figure 6.4). The vertical loads are normally just a proportion of the self-weight of the panel whilst the horizontal loads may be induced by wind and/or seismic effects.

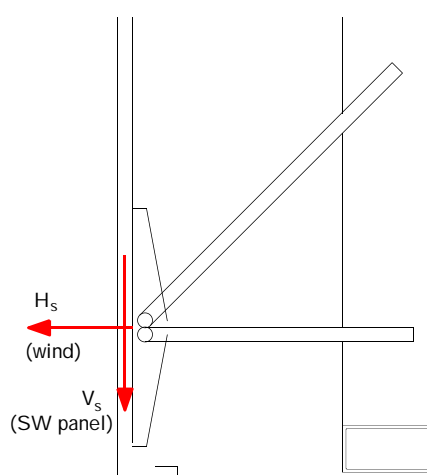

Figure 6.4

6.7 Seismic Effects

Figure 6.5 (a) and (b) show elevations on a rectangular, flat ribbed panel that is not required to resist seismic effects. Shrinkage and thermal movements are accommodated by three of the fixings, as shown in Figure 6.5 (a), thereby avoiding distress to the panel. The self weight of the panel (W) is supported equally at the two fixings at the base of the panel (Figure 6.5 (b)) whilst lateral wind loads, acting perpendicular to the face of the panel, are resisted by all four fixings.

In simple terms, the effect of seismic loading is to impose a horizontal load (S) at the centre of gravity of the panel due to horizontal accelerations of the ground beneath (Figure 6.5 (c)). This force can act in the plane of the panel or perpendicular to the panel. The former case of seismic loading is the one considered here.

Assuming the upper two fixings cannot offer any resistance to the seismic load, the overturning moment ($= S \times h$) causes a redistribution of the vertical reactions at the base of the panel to $0.5 W + (S \cdot h/L)$ and $0.5 W - (S \cdot h/L)$ respectively. In addition, a horizontal reaction (S) is developed at the 'fixed' fixing at the base of the panel (Figure 6.5 (c)).

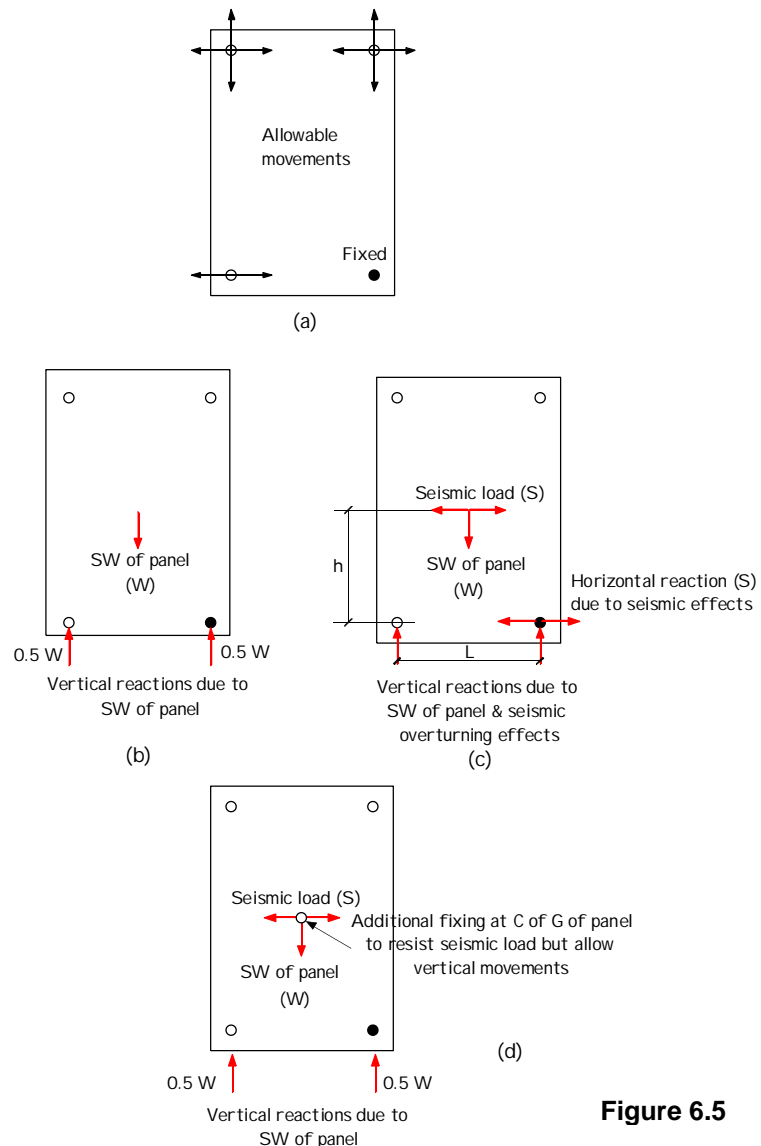

Figure 6.5

Clearly, if an additional fixing allowing only vertical movement were to be introduced at the centre of gravity of the panel, as shown in Figure 6.5 (d), the seismic loading would be fully resisted by this fixing and so the fixings at the base of the panel would only be required to support the self weight of the panel as normal.

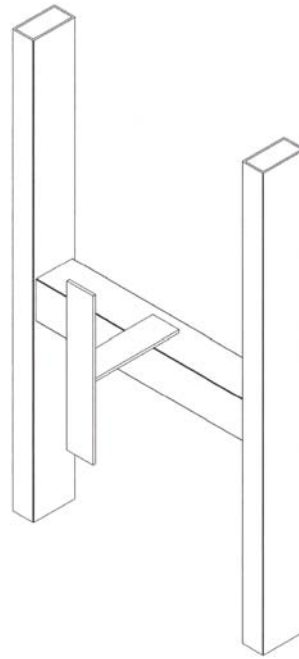

Figure 6.6

The same principles apply to stud frame construction in that a fabricated T-fixing, like that shown in Figure 6.6, could be bonded at the centre of gravity of the panel and

7

WORKED EXAMPLES

The following worked examples are only intended to demonstrate the use of the partial factors of safety in practical design. However, the GRCA International does not accept any liability whatsoever for any direct, indirect, consequential or incidental loss or damage resulting from the use of this Practical Design Guide, the included software, the worked examples and partial factors of safety supplied or used in this Design Guide.

Further examples and errata (if necessary) will be posted on the GRCA website <http://www.grca.org.uk> for free downloading by registered individuals or Companies.

The worked examples are as follows:

Example 1	Simple Cladding Panel
Example 2	Permanent Formwork
Example 3	Permanent Formwork
Example 4	Planter (ribbed panels)
Example 5	Portico Roof (Stud Frame Construction)
Example 6	Circular Planter
Example 7	String Course Feature
Example 8	Coping Unit
Example 9	Cable Duct (in ground)
Example 10	Sunscreen
Example 11	Flex Anchor
Example 12	Gravity Anchor

In each of these worked examples a *grade* of GRC is specified. Reference should be made to the International GRCA Publication 'Specification for the Manufacture, Curing and Testing of GRC Products' for detailed information about the grading of GRC mixes. In all of the above worked examples, the grade of the GRC mixes is specified in the format: Grade(X/Y), where X = Characteristic LOP at 28 days and Y = Characteristic MOR at 28 days.

When a GRC product is mainly subjected to direct tension, it is appropriate to use the ultimate direct design strength at 28 days when checking conformance to the ultimate limit state (ULS). This strength can be taken as $0.4 \times \text{MOR}_{28}$ for design purposes. The serviceability direct tensile design is usually taken as $\text{BOP}_{28}/1.8$, where BOP_{28} is the characteristic bend over point at 28 days. This is usually taken as $\text{BOP}_{28} = \text{LOP}_{28}/\gamma_m$, where the *global* factor of safety γ_m equals 1.8. Worked Example 6 shows how the above estimates are used in a practical design.

worked example - for demonstration purposes only

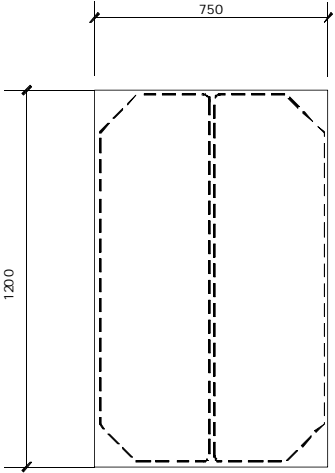
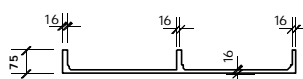
Title: Design Examples - Example No 1 - Simple Cladding Panel				Drg Ref		
Project No Ex1	By A R Glass	Checked Al Ways	Date Oct-03	Sheet No 1 of 3	Rev	
REF	CALCULATIONS					OUTPUT
	<p style="text-align: center;">Cladding Panel - Grade (8/18)</p> <div style="display: flex; justify-content: space-around; align-items: center;"> <div style="text-align: center;">  </div> <div style="text-align: left;"> <p>$\gamma_f^1 = 1.40$ $\gamma_{tv} = 1.00$ $\gamma_b = 1.02$ $\gamma_c = 1.10$ Bending: $\gamma_m = 3$ (ULS) $\gamma_m = 1.8$ (SLS) Interlaminar Shear: $\gamma_m = 1.7$ (ULS)</p> </div> </div> <div style="text-align: center; margin-top: 10px;">  </div> <p>Check vertical bending <u>Ultimate Limit State</u> $\gamma_f = 1.4 \times 1 \times 1.02 \times 1.10 = 1.57$ Wind loading = 1.5 kN/m^2, hence $M_u = 1.57 \times 1.5 \times 0.75 \times 1.2 \times 1.2 / 8 = 0.32 \text{ kNm}$ $\text{Min } Z = 7.1852 \times 10^4 \text{ mm}^3$ Ultimate bending stress = σ_u $= 0.32 \times 10^6 / 7.1852 \times 10^4$ $= 4.45 \text{ N/mm}^2$ Allow for shrinkage stress σ_{ss} of 0.6 N/mm^2 and thermal stress σ_{ts} of 0.4 N/mm^2, hence MOR required @ 28 days = $3 \times (4.45 + 0.6 + 0.4)$ $= 16.35 \text{ N/mm}^2$ $< 18 \text{ N/mm}^2 \text{ OK}$ Check interlaminar shear resistance $V_u = 1.57 \times 1.5 \times 0.75 \times 1.2 / 2 = 1.06 \text{ kN}$ Hence, $v_u = (1.5 \times 1.06 \times 1000) / (3 \times 75 \times 16) = 0.44 \text{ N/mm}^2$</p>					
						<p>MOR @ 28 days = 18 N/sqr mm</p>

worked example - for demonstration purposes only

Title: Design Examples - Example No 1 - Simple Cladding Panel				Drg Ref		
Project No Ex1	By A R Glass	Checked AI Ways	Date Oct-02	Sheet No 2 of 3	Rev	
REF	CALCULATIONS					OUTPUT
	<p>Characteristic interlaminar shear strength required at 28 days = $1.7 \times 0.44 = 0.75 \text{ N/mm}^2 < 2 \text{ N/mm}^2$ and $< 0.4 \times \text{LOP} = 0.4 \times 8 = \underline{3.2 \text{ N/mm}^2}$ OK</p> <p><u>Serviceability Limit State</u> Global material safety factor = 1.8 $M_s = 1.5 \times 0.75 \times 1.2 \times 1.2 / 8 = 0.2 \text{ kNm}$ Service bending stress = $\sigma_s = 0.2 \times 10^6 / 7.1852 \times 10^4 = \underline{2.78 \text{ N/mm}^2}$ LOP required @ 28 days = $1.8 \times (2.78 + 0.6 + 0.4) = \underline{6.80 \text{ N/mm}^2}$ $< 8 \text{ N/mm}^2$ OK</p> <p>Check deflection Assume $E_s = 10 \text{ kN/mm}^2$ $y_s = (5 \times 1.5 \times 1.2 \times 0.75 \times 1200^3) / (384 \times 10 \times 4.2996 \times 10^6) = \underline{0.71 \text{ mm}}$ negligible</p> <p>Check 16mm thk skin <u>Ultimate Limit State</u> I dealise skin as a two span beam with equal spans of 375mm $M_u = 0.625 \times 1.57 \times 1.5 \times 0.375^2 = \underline{0.21 \text{ kNm}}$ $Z = 1000 \times 16^2 / 6 = 4.27 \times 10^4 \text{ mm}^3$ Ultimate bending stress = $\sigma_u = 0.21 \times 10^6 / 4.27 \times 10^4 = \underline{4.92 \text{ N/mm}^2}$ MOR required @ 28 days = $3 \times (4.92 + 0.6 + 0.4) = \underline{17.8 \text{ N/mm}^2}$</p> <p><u>Serviceability Limit State</u> Global material safety factor = 1.8 $M_s = 0.625 \times 1.5 \times 0.375^2 = 0.13 \text{ kNm}$ Service bending stress = $\sigma_s = 0.13 \times 10^6 / 4.27 \times 10^4 = \underline{3.05 \text{ N/mm}^2}$ LOP required @ 28 days = $1.8 \times (3.05 + 0.6 + 0.4) = \underline{7.29 \text{ N/mm}^2}$ $< 8 \text{ N/mm}^2$ OK</p> <p>Shear/deflection not critical</p>					<p>LOP @ 28 days = 8 N/sqr mm</p> <p>MOR @ 28 days = 18 N/sqr mm</p> <p>LOP @ 28 days = 8 N/sqr mm</p>

worked example - for demonstration purposes only

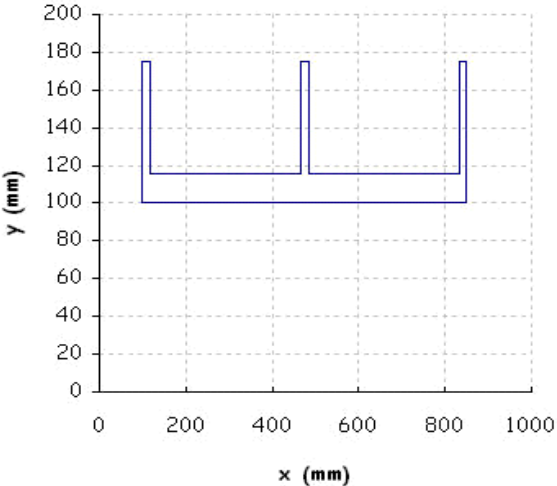
Title: Design Examples - Example No 1 - Simple Cladding Panel					Drg Ref																																																														
Project No Ex1	By A R Glass	Checked Al Ways	Date Oct-02	Sheet No 3 of 3	Rev																																																														
REF	CALCULATIONS						OUTPUT																																																												
	<div style="text-align: center;">  </div> <p>Section Properties</p> <table> <tr><td>No of coordinates</td><td>=</td><td>13</td></tr> <tr><td>Area</td><td>=</td><td>1.4832E+04 mm²</td></tr> <tr><td>Xbar</td><td>=</td><td>475.0 mm</td></tr> <tr><td>Ybar</td><td>=</td><td>115.2 mm</td></tr> <tr><td>I_{xx}</td><td>=</td><td>4.2996E+06 mm⁴</td></tr> <tr><td>I_{yy}</td><td>=</td><td>8.1685E+08 mm⁴</td></tr> <tr><td>I_{xy}</td><td>=</td><td>0.0000E+00 mm⁴</td></tr> <tr><td>I_{uu}</td><td>=</td><td>4.2996E+06 mm⁴</td></tr> <tr><td>I_w</td><td>=</td><td>8.1685E+08 mm⁴</td></tr> <tr><td>Theta</td><td>=</td><td>0.000 deg</td></tr> <tr><td>Z_t</td><td>=</td><td>7.1852E+04 mm³</td></tr> <tr><td>Z_b</td><td>=</td><td>2.8361E+05 mm³</td></tr> <tr><td>Z_l</td><td>=</td><td>2.1783E+06 mm³</td></tr> <tr><td>Z_r</td><td>=</td><td>2.1783E+06 mm³</td></tr> <tr><td>Z_{uu}</td><td>=</td><td>7.1852E+04 mm³</td></tr> <tr><td>Z_w</td><td>=</td><td>2.1783E+06 mm³</td></tr> <tr><td>r_{xx}</td><td>=</td><td>17.0 mm</td></tr> <tr><td>r_{yy}</td><td>=</td><td>234.7 mm</td></tr> <tr><td>r_{uu}</td><td>=</td><td>17.0 mm</td></tr> <tr><td>r_w</td><td>=</td><td>234.7 mm</td></tr> </table>						No of coordinates	=	13	Area	=	1.4832E+04 mm ²	Xbar	=	475.0 mm	Ybar	=	115.2 mm	I _{xx}	=	4.2996E+06 mm ⁴	I _{yy}	=	8.1685E+08 mm ⁴	I _{xy}	=	0.0000E+00 mm ⁴	I _{uu}	=	4.2996E+06 mm ⁴	I _w	=	8.1685E+08 mm ⁴	Theta	=	0.000 deg	Z _t	=	7.1852E+04 mm ³	Z _b	=	2.8361E+05 mm ³	Z _l	=	2.1783E+06 mm ³	Z _r	=	2.1783E+06 mm ³	Z _{uu}	=	7.1852E+04 mm ³	Z _w	=	2.1783E+06 mm ³	r _{xx}	=	17.0 mm	r _{yy}	=	234.7 mm	r _{uu}	=	17.0 mm	r _w	=	234.7 mm	
No of coordinates	=	13																																																																	
Area	=	1.4832E+04 mm ²																																																																	
Xbar	=	475.0 mm																																																																	
Ybar	=	115.2 mm																																																																	
I _{xx}	=	4.2996E+06 mm ⁴																																																																	
I _{yy}	=	8.1685E+08 mm ⁴																																																																	
I _{xy}	=	0.0000E+00 mm ⁴																																																																	
I _{uu}	=	4.2996E+06 mm ⁴																																																																	
I _w	=	8.1685E+08 mm ⁴																																																																	
Theta	=	0.000 deg																																																																	
Z _t	=	7.1852E+04 mm ³																																																																	
Z _b	=	2.8361E+05 mm ³																																																																	
Z _l	=	2.1783E+06 mm ³																																																																	
Z _r	=	2.1783E+06 mm ³																																																																	
Z _{uu}	=	7.1852E+04 mm ³																																																																	
Z _w	=	2.1783E+06 mm ³																																																																	
r _{xx}	=	17.0 mm																																																																	
r _{yy}	=	234.7 mm																																																																	
r _{uu}	=	17.0 mm																																																																	
r _w	=	234.7 mm																																																																	

worked example - for demonstration purposes only

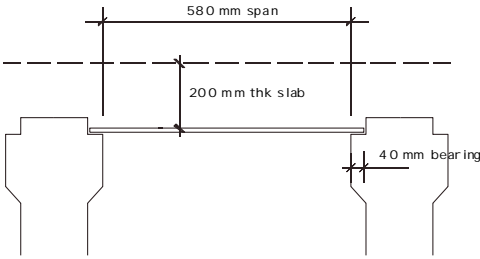
Title: Design Examples - Example No 2 - Permanent Formwork				Drg Ref		
Project No Ex2	By A R Glass	Checked AI Ways	Date Oct-03	Sheet No 1 of 2	Rev	
REF	CALCULATIONS					OUTPUT
	<p>Permanent Formwork - Flat sheet Grade (9/18)</p>  <p>Try 18mm thk flat sheet</p> <p> $\gamma_f' = 1.40$ (DL) $\gamma_f' = 1.60$ (LL) $\gamma_{tv} = 1.00$ $\gamma_b = 1.00$ $\gamma_c = 1.20$ Bending: $\gamma_m = 1.7$ (ULS) $\gamma_m = 1.4$ (SLS) Interlaminar Shear: $\gamma_m = 1.7$ (ULS) </p> <p><u>Ultimate Limit State</u></p> <p>Concrete $0.2 \times 24 = 4.8 \text{ kN/m}^2$ Live load $= 1.5 \text{ kN/m}^2$ (construction load) SW $0.018 \times 20 = 0.36 \text{ kN/m}^2$ say 0.45 kN/m^2 (25% overspray) Ultimate load / sqm $= 1.4 (0.45 + 4.8) + (1.6 \times 1.5)$ $= 9.75 \text{ kN/m}^2$ Ultimate design load $= 1.0 \times 1.0 \times 1.2 \times 9.75$ $= 11.7 \text{ kN/m}^2$ $M_u = 11.7 \times 0.62 \times 0.62 / 8 = 0.56 \text{ kNm}$ $Z = 1000 \times 18 \times 18 / 6 = 5.4 \times 10^4 \text{ mm}^3$ Ultimate bending stress $= \sigma_u$ $= 0.56 \times 10^6 / 5.4 \times 10^4$ $= 10.37 \text{ N/mm}^2$ MOR required @ 28 days $= 1.7 \times 10.37$ $= 17.6 \text{ N/mm}^2$ $< 18 \text{ N/mm}^2$ OK </p> <p>Check interlaminar shear resistance $V_u = 11.7 \times 1 \times 0.62 / 2 = 3.63 \text{ kN}$ $v_u = (1.5 \times 3.63 \times 10^3) / (1000 \times 18) = 0.3 \text{ N/mm}^2$ Characteristic interlaminar shear strength required at 28 days $= 1.7 \times 0.3 = 0.51 \text{ N/mm}^2$ $< 0.4 \times \text{LOP} = 0.4 \times 7 = 2.8 \text{ N/mm}^2$ OK </p>					
						MOR @ 28 days = 18 N/sqr mm

worked example - for demonstration purposes only

REF		CALCULATIONS				OUTPUT
		<p><u>Serviceability Limit State</u></p> <p>Global factor of safety = 1.5 (temporary works)</p> $M_s = (4.8 + 1.5 + 0.45) \times 0.62 \times 0.62 / 8 = 0.32 \text{ kNm}$ <p>Service bending stress = σ_s</p> $= (0.32 \times 10^6) / 5.4 \times 10^4$ $= 5.93 \text{ N/sqr mm}$ <p>LOP required @ 28 days = $1.4 \times 5.93 = \underline{8.3 \text{ N/sqr mm}}$</p> <p style="text-align: right;">< 9 N/sqr mm OK</p> <p><u>Deflection not critical</u></p>				<p>LOP @ 28 days = 9 N/sqr mm</p>

Title: Design Examples - Example No 2 - Permanent Formwork				Drg Ref		
Project No Ex2	By A R Glass	Checked AI Ways	Date Oct-03	Sheet No 2 of 2	Rev	

worked example - for demonstration purposes only

Title: Design Examples - Example No 3 - Permanent Formwork				Drg Ref		
Project No Ex3	By A R Glass	Checked AI Ways	Date Oct-03	Sheet No 2 of 3	Rev	
REF	CALCULATIONS					OUTPUT
	<p>Ultimate design load = $1.68 \times (1.08 + 0.11 + 0.06)$ $+ (1.92 \times 0.45)$ $= 2.96 \text{ kN/m}$</p> <p>$M_u = 2.96 \times 0.89 \times 0.89 / 8 = 0.29 \text{ kNm}$</p> <p>Ultimate bending stress $\sigma_s = 0.29 \times 10^6 / 2.7935 \times 10^4$ $= 10.38 \text{ N/mm}^2$</p> <p>MOR required at 28 days = 1.7×10.38 $= 17.65 \text{ N/mm}^2$ $< 18 \text{ N/mm}^2 \text{ OK}$</p> <p>Check interlaminar shear resistance Assume thk of edge = 8 mm $V_u = 2.96 \times 0.89 / 2 = 1.32 \text{ kN}$ Hence, $v_u = 1.5 \times 1.32 \times 10^3 / (300 \times 8) = 0.83 \text{ N/mm}^2$ Characteristic interlaminar shear strength required at 28 days = $1.7 \times 0.83 = 1.41 \text{ N/mm}^2 < 2 \text{ N/mm}^2$ and $< 0.4 \times \text{LOP} = 0.4 \times 8 = 3.2 \text{ N/mm}^2 \text{ OK}$</p> <p><u>Serviceability Limit State</u> Global factor of safety = 1.4 (temporary works)</p> <p>$M_s = (1.08 + 0.11 + 0.06 + 0.45) \times 0.89 \times 0.89 / 8$ $= 0.17 \text{ kNm}$</p> <p>Service bending stress = σ_s $= (0.17 \times 10^6) / 2.7935 \times 10^4$ $= 6.09 \text{ N/sqr mm}$</p> <p>LOP required @ 28 days = $1.4 \times 6.09 = 8.53 \text{ N/sqr mm}$ $< 9 \text{ N/sqr mm OK}$</p>					
						LOP @ 28 days = 9 N/sqr mm

worked example - for demonstration purposes only

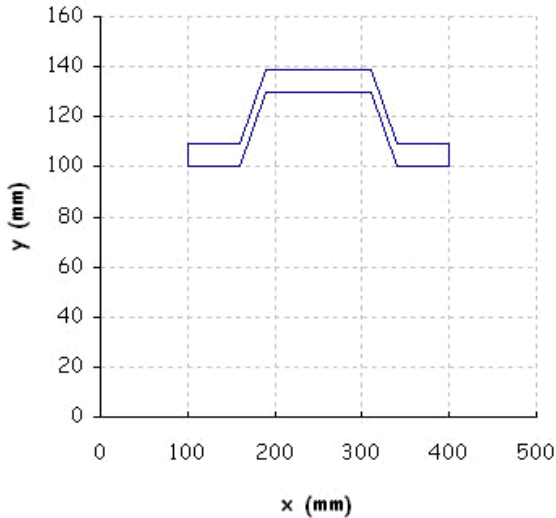
Title: Design Examples - Example No 3 - Permanent Formwork				Drg Ref		
Project No Ex3	By A R Glass	Checked AI Ways	Date Oct-03	Sheet No 3 of 3	Rev	
REF	CALCULATIONS					OUTPUT
	<p>SECTPROP Results</p>  <p style="text-align: center;">Section Properties</p> <p>No of coordinates = 13</p> <p>Area = 2.7000E+03 mm²</p> <p>X_{bar} = 250.0 mm</p> <p>Y_{bar} = 119.5 mm</p> <p>I_{xx} = 5.4473E+05 mm⁴</p> <p>I_{yy} = 2.0250E+07 mm⁴</p> <p>I_{xy} = 0.0000E+00 mm⁴</p> <p>I_{uu} = 5.4473E+05 mm⁴</p> <p>I_{vv} = 2.0250E+07 mm⁴</p> <p>Theta = 0.000 deg</p> <p>Z_t = 2.7935E+04 mm³</p> <p>Z_b = 2.7935E+04 mm³</p> <p>Z_l = 1.3500E+05 mm³</p> <p>Z_r = 1.3500E+05 mm³</p> <p>Z_{uu} = 2.7935E+04 mm³</p> <p>Z_{vv} = 1.3500E+05 mm³</p> <p>r_{xx} = 14.2 mm</p> <p>r_{yy} = 86.6 mm</p> <p>r_{uu} = 14.2 mm</p> <p>r_{vv} = 86.6 mm</p>					

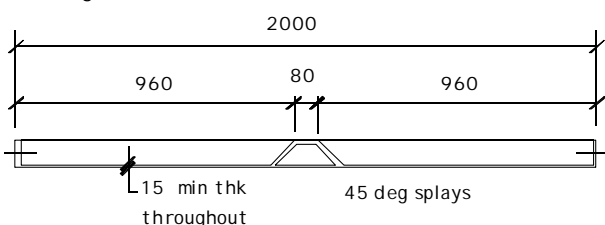

worked example - for demonstration purposes only

Title: Design Examples - Example No 4 - Planter				Drg Ref		
Project No Ex4	By A R Glass	Checked AI Ways	Date Oct-03	Sheet No 2 of 3	Rev	
REF	CALCULATIONS					OUTPUT
	<p>Ultimate Limit State</p> $\gamma_f = 1.4 \times 1.05 \times 1.05 \times 1 = 1.54$ $M_u = 1.54 \times 4 \times 1 \times 2^2 / 8 = 3.08 \text{ kNm}$ $Z \text{ for outer face} = 8.0649 \times 10^5 \text{ mm}^3$ $\text{Ultimate bending stress } \sigma_u = 3.08 \times 10^6 / 8.0649 \times 10^5$ $= 3.82 \text{ N/mm}^2 \text{ (tension)}$ <p>Allow for shrinkage stress σ_{ss} of 0.5 N/mm^2 and thermal stress σ_{ts} of 0.2 N/mm^2, hence</p> $\text{MOR required @ 28 days} = 2.7 \times (3.82 + 0.5 + 0.2)$ $= 12.20 \text{ N/mm}^2 < 18 \text{ N/mm}^2$ <p style="text-align: right;">OK</p> <p>Check interlaminar shear resistance</p> $V_u = 1.54 \times 4 \times 1 \times 2 / 2 = 6.16 \text{ kN}$ <p>Hence,</p> $v_u = (1.5 \times 6.16 \times 10^3) / (5 \times 15 \times 100)$ $= 1.23 \text{ N/mm}^2$ <p>Characteristic interlaminar shear strength required at 28 days = $1.7 \times 1.23 = 2.09 \text{ N/mm}^2$</p> $< 0.4 \times \text{LOP} = 0.4 \times 7 = 2.8 \text{ N/mm}^2 \quad \text{OK}$ <p>Serviceability Limit State</p> <p>Global material safety factor = 1.8</p> $M_s = 4 \times 1 \times 2^2 / 8 = 2 \text{ kNm}$ <p>Service bending stress = σ_s</p> $= 2 \times 10^6 / 8.0649 \times 10^5$ $= 2.48 \text{ N/mm}^2$ <p>LOP required @ 28 days = $1.8 \times (2.48 + 0.5 + 0.2)$</p> $= 5.72 \text{ N/mm}^2 < 7 \text{ N/mm}^2 \quad \text{OK}$ <p>Deflection not critical</p> <p>Provide a vertical, central box rib to obviate any vertical bending effects as shown below.</p> 					<p>MOR @ 28 days = 18 N/sqr mm</p> <p>LOP @ 28 days = 7 N/sqr mm</p>

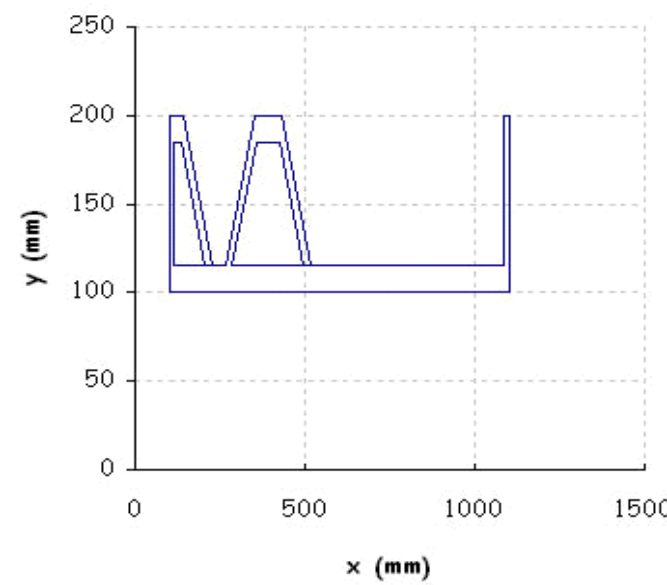
worked example - for demonstration purposes only

Title: Design Examples - Example No 4 - Planter					Drg Ref		
Project No Ex4	By A R Glass	Checked Al Ways	Date Oct-03	Sheet No 3 of 3	Rev		
REF	CALCULATIONS						OUTPUT
							
	<p>Section Properties</p> <p>No of coordinates = 25</p> <p>Area = 2.3873E+04 mm²</p> <p>X_{bar} = 526.1 mm</p> <p>Y_{bar} = 127.5 mm</p> <p>I_{xx} = 2.2151E+07 mm⁴</p> <p>I_{yy} = 2.3194E+09 mm⁴</p> <p>I_{xy} = -6.2510E+07 mm⁴</p> <p>I_{uu} = 2.0452E+07 mm⁴</p> <p>I_{vv} = 2.3211E+09 mm⁴</p> <p>Theta = -1.557 deg</p> <p>Z_t = 3.0539E+05 mm³</p> <p>Z_b = 8.0649E+05 mm³</p> <p>Z_l = 5.4429E+06 mm³</p> <p>Z_r = 4.0418E+06 mm³</p> <p>Z_{uu} = 2.3213E+05 mm³</p> <p>Z_{vv} = 4.0410E+06 mm³</p> <p>r_{xx} = 30.5 mm</p> <p>r_{yy} = 311.7 mm</p> <p>r_{uu} = 29.3 mm</p> <p>r_{vv} = 311.8 mm</p>						

worked example - for demonstration purposes only

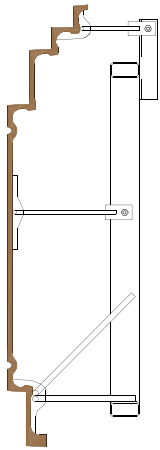
Title: Design Examples - Example No 5 - Portico Roof				Drg Ref				
Project No Ex5	By A R Glass	Checked AI Ways	Date Oct-03	Sheet No 1 of 2	Rev			
REF	CALCULATIONS					OUTPUT		
								
	Curved Fascia Panel (Studframe) - Grade (7/18)							
	<table style="width: 100%; border: none;"> <tr> <td style="width: 50%; vertical-align: top;"> γ_f^* = 1.40 γ_{tw} = 1.00 γ_b = 1.02 γ_c = 1.10 </td> <td style="width: 50%; vertical-align: top;"> Bending: γ_m = 3 (ULS) γ_m = 1.8 (SLS) Interlaminar Shear: γ_m = 1.7 (ULS) </td> </tr> </table>					γ_f^* = 1.40 γ_{tw} = 1.00 γ_b = 1.02 γ_c = 1.10	Bending: γ_m = 3 (ULS) γ_m = 1.8 (SLS) Interlaminar Shear: γ_m = 1.7 (ULS)	
γ_f^* = 1.40 γ_{tw} = 1.00 γ_b = 1.02 γ_c = 1.10	Bending: γ_m = 3 (ULS) γ_m = 1.8 (SLS) Interlaminar Shear: γ_m = 1.7 (ULS)							
	Spacings of flex/gravity anchors: Vertical 500mm Horizontal 600mm (approx)							
	Try GRC thickness of 15mm (min)							
	Ultimate Limit State $\gamma_f = 1.4 \times 1 \times 1.02 \times 1.10 = 1.57$ Wind loading = 1.5 kN/m ² , hence $M_u = 1.57 \times 1.5 \times 0.5 \times 0.6 \times 0.6 / 8$ = 0.05 kNm							
	$Z = 500 \times 15^2 / 6 = 1.875 \times 10^4 \text{ mm}^3$ Ultimate bending stress = σ_u = $0.05 \times 10^6 / 1.875 \times 10^4$ = 2.67 N/mm ²							

worked example - for demonstration purposes only

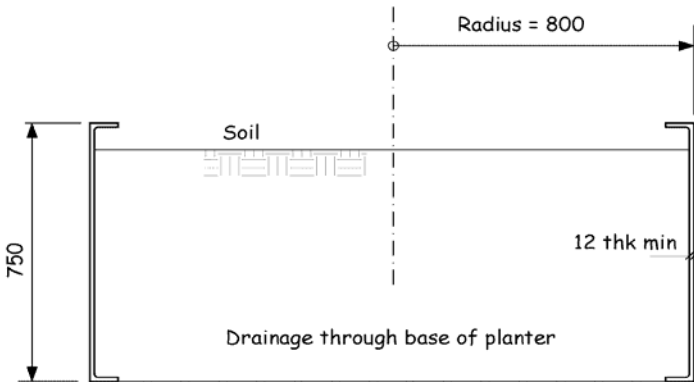
Title: Design Examples - Example No 6 - Circular Planter					Drg Ref		
Project No Ex6	By A R Glass	Checked AI Ways	Date Oct-03	Sheet No 1 of 2	Rev		
REF	CALCULATIONS						OUTPUT
	 <p style="text-align: center;">Circular GRC Planter - Grade (7/18)</p> <p>Assume soil density $\gamma = 18 \text{ kN/m}^3$ (no water pressure) Coefficient of active pressure = 0.33.</p> <p> γ_r^* = 1.40 γ_{tv} = 1.05 $UTS_{28} = 0.4 \times 18 = 7.2 \text{ N/mm}^2$ γ_b = 1.05 γ_c = 1.00 $BOP_{28} = 7/1.5 = 4.7 \text{ N/mm}^2$ </p> <p>Direct tension: γ_m = 3 (ULS) γ_m = 1.8 (SLS) </p> <p>Interlaminar Shear: Not critical</p> <p>Ultimate Limit State γ_r = $1.4 \times 1.05 \times 1.05 \times 1 = 1.54$ </p> <p>Pressure p Earth pressure at base of planter = $0.33 \times 18 \times 0.75 = 4.5 \text{ kN/m}^2$ </p> <p>= pr/t Ultimate ring tension = $1.54 \times 4.5 \times 800 / 12 \times 10^3 = 0.46 \text{ N/mm}^2$ </p> <p>Allow for shrinkage stress σ_{ss} of 0.5 N/mm^2 and thermal stress σ_{ts} of 1.2 N/mm^2, hence UTS required at 28 days = $3 \times (0.46 + 0.5 + 1.2) = 6.5 \text{ N/mm}^2 < 7.2 \text{ N/mm}^2$ OK </p>						
							MOR @ 28 days = 18 N/sqr mm

worked example - for demonstration purposes only

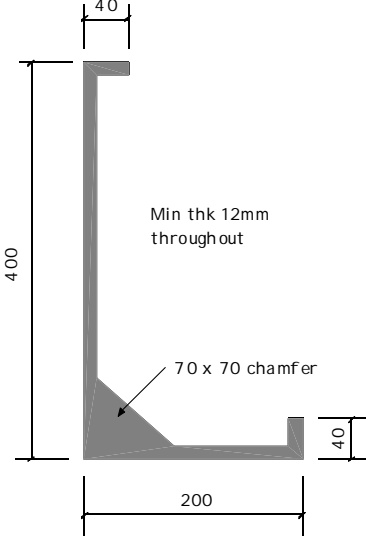
Title: Design Examples - Example No 7 - Stringcourse				Drg Ref		
Project No Ex7	By A R Glass	Checked AI Ways	Date Oct-03	Sheet No 1 of 3	Rev	
REF	CALCULATIONS					OUTPUT
	 <p style="text-align: center;">GRC Stringcourse Unit - Grade (7/18)</p> <p> $\gamma_f' = 1.40$ $\gamma_{tv} = 1.10$ $\gamma_b = 1.02$ $\gamma_c = 1.00$ </p> <p>Span = 1.80m (simply supported)</p> <p>Bending: $\gamma_m = 3$ (ULS) $\gamma_m = 1.8$ (SLS) </p> <p>Wind loading: 2 kN/m²</p> <p>Interlaminar Shear: $\gamma_m = 1.7$ (ULS) </p> <p>Ultimate Limit State $\gamma_f = 1.4 \times 11 \times 1.052 \times 1.1 = 1.73$ Self Wt = 0.0102 x 20 x 1.8 = 0.37 kN say 0.46 kN (25% overspray) $M_{ux} = 1.73 \times 0.46 \times 1.8 / 8 = 0.18$ kNm $M_{uy} = 1.73 \times 2 \times 4 \times 1.8^2 / 8 = 0.56$ kNm $M_{uu} = 0.18 \cos(13.476) + 0.56 \sin(13.476) = 0.31$ kNm $M_{vv} = 0.18 \sin(13.476) + 0.56 \cos(13.476) = 0.59$ kNm Combined ultimate bending stress $\sigma_u =$ $(0.31 \times 10^6) / (1.181 \times 10^6) + (0.59 \times 10^6) / (1.6477 \times 10^5)$ $= 3.84$ N/mm² (z_{uu} for btm fibres calculated from I_{uu}) </p>					

worked example - for demonstration purposes only

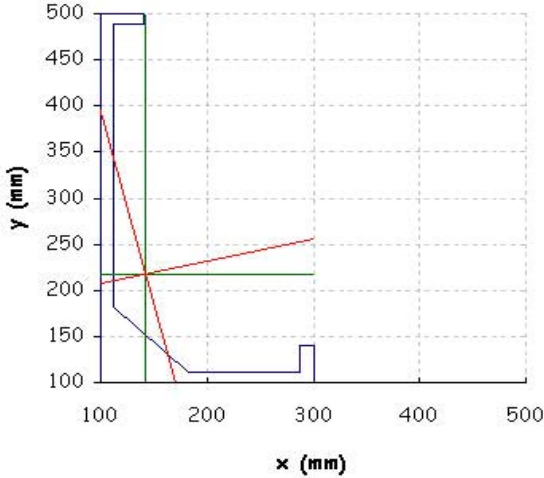
Title: Design Examples - Example No 7 - Stringcourse					Drg Ref		
Project No Ex7	By A R Glass	Checked AI Ways	Date Oct-03	Sheet No 3 of 3	Rev		
REF	CALCULATIONS						OUTPUT
							
	<p>Section Properties</p> <p>No of coordinates = 12</p> <p>Area = 1.0178E+04 mm²</p> <p>\bar{x} = 142.1 mm</p> <p>\bar{y} = 218.0 mm</p> <p>I_{xx} = 1.7048E+08 mm⁴</p> <p>I_{yy} = 3.0814E+07 mm⁴</p> <p>I_{xy} = -3.5506E+07 mm⁴</p> <p>I_{uu} = 1.7898E+08 mm⁴</p> <p>I_{ww} = 2.2306E+07 mm⁴</p> <p>Theta = 13.476 deg</p> <p>Z_t = 6.0457E+05 mm³</p> <p>Z_b = 1.4445E+06 mm³</p> <p>Z_l = 7.3205E+05 mm³</p> <p>Z_r = 1.9514E+05 mm³</p> <p>Z_{uu} = 6.3017E+05 mm³</p> <p>Z_{ww} = 1.6477E+05 mm³</p> <p>r_{xx} = 129.4 mm</p> <p>r_{yy} = 55.0 mm</p> <p>r_{uu} = 132.6 mm</p> <p>r_{ww} = 46.8 mm</p>						

worked example - for demonstration purposes only

Title: Design Examples - Example No 8 - Coping Unit				Drg Ref		
Project No Ex8	By A R Glass	Checked AI Ways	Date Oct-03	Sheet No 2 of 3	Rev	
REF	CALCULATIONS					OUTPUT
	<p>Characteristic interlaminar shear strength required at 28 days = $1.7 \times 0.74 = 1.26 \text{ N/mm}^2$ $< 0.4 \times \text{LOP}_{28} = 0.4 \times 7 = 2.8 \text{ N/mm}^2$ OK</p> <p>Serviceability Limit State Global material safety factor = 1.8 $M_s = 1.8^2 \times ((1.5 \times 0.34) + 0.18) / 8 = 0.28 \text{ kNm}$ Service bending stress = $\sigma_s = 0.28 \times 10^6 / 1.32 \times 10^5$ $= 2.12 \text{ N/mm}^2$ LOP required @ 28 days = $1.8 \times (2.12 + 0.6 + 0.5)$ $= 5.8 \text{ N/mm}^2$ $< 7 \text{ N/mm}^2$ OK</p> <p>Deflection not critical</p>					<p>LOP @ 28 days = 7 N/sqr mm</p>

worked example - for demonstration purposes only

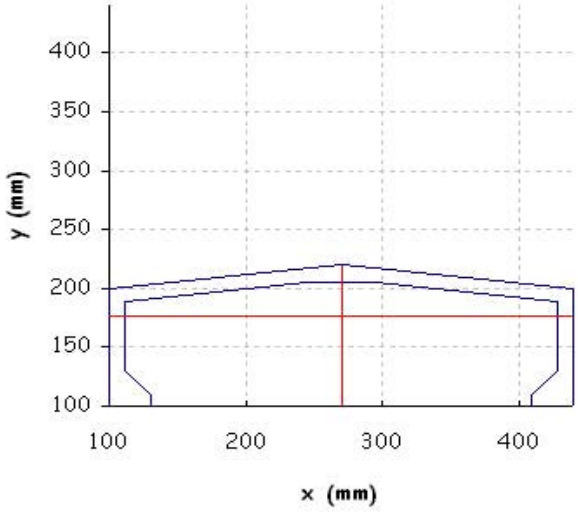
Title: Design Examples - Example No 8 - Coping Unit					Drg Ref		
Project No Ex8	By A R Glass	Checked AI Ways	Date Oct-03	Sheet No 3 of 3	Rev		
REF	CALCULATIONS						OUTPUT
							
	<p>Section Properties</p> <p>No of coordinates = 16</p> <p>Area = 7.0680E+03 mm²</p> <p>X_{bar} = 270.0 mm</p> <p>Y_{bar} = 176.5 mm</p> <p>I_{xx} = 1.0096E+07 mm⁴</p> <p>I_{yy} = 1.1372E+08 mm⁴</p> <p>I_{xy} = 0.0000E+00 mm⁴</p> <p>I_{uu} = 1.0096E+07 mm⁴</p> <p>I_{vv} = 1.1372E+08 mm⁴</p> <p>Theta = 0.000 deg</p> <p>Z_t = 2.3203E+05 mm³</p> <p>Z_b = 1.3200E+05 mm³</p> <p>Z_l = 6.6894E+05 mm³</p> <p>Z_r = 6.6894E+05 mm³</p> <p>Z_{uu} = 1.3200E+05 mm³</p> <p>Z_{vv} = 6.6894E+05 mm³</p> <p>r_{xx} = 37.8 mm</p> <p>r_{yy} = 126.8 mm</p> <p>r_{uu} = 37.8 mm</p> <p>r_{vv} = 126.8 mm</p>						

worked example - for demonstration purposes only

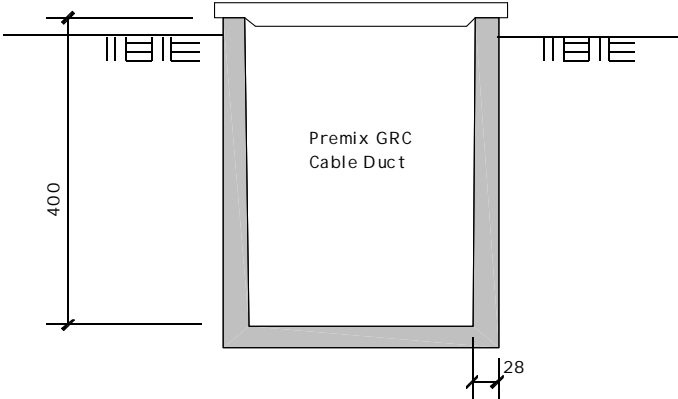
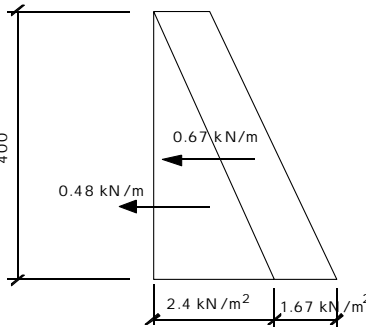
Title: Design Examples - Example No 9 - Cable Duct				Drg Ref		
Project No Ex9	By A R Glass	Checked AI Ways	Date Oct-03	Sheet No 1 of 2	Rev	
REF	CALCULATIONS					OUTPUT
	 <p style="text-align: center;">GRC Cable Duct - Grade (6/10) - Premix</p> <p>Assume soil density $\gamma = 18 \text{ kN/m}^3$ (no water pressure) Soil friction angle $\phi = 30 \text{ deg}$.</p> <p>$\gamma_f' = 1.40$ $\gamma_{tv} = 1.05$ $\gamma_b = 1.05$ $\gamma_c = 1.00$</p> <p>Bending: $\gamma_m = 3$ (ULS) $\gamma_m = 1.8$ (SLS)</p> <p>Interlaminar Shear: $\gamma_m = 1.7$ (ULS)</p> <p>$K_a = (1 - \sin \phi) / (1 + \sin \phi) = 0.33$ Soil pressure at base of duct $= 0.33 \times 18 \times 0.4$ $= 2.4 \text{ kN/m}^2$</p> <p>Allow surcharge of 5 kN/m^2</p>  <p>hence, lateral surcharge pressure $= 0.33 \times 5$ $= 1.67 \text{ kN/m}^2$</p>					

worked example - for demonstration purposes only

Design Examples - Example No 10 - Sunscreen				Drg Ref		
Project No Ex10	By A R Glass	Checked AI Ways	Date Oct-03	Sheet No 2 of 3	Rev	
REF	CALCULATIONS					OUTPUT
	<p>Check interlaminar shear resistance</p> $V_u / \text{edge} = 1.54 \times 0.62 \times 0.8 \times 1.24 \times 0.8 / 2$ $= 0.38 \text{ kN}$ $v_u / \text{edge} = 1.5 \times 0.38 \times 10^3 / (90 \times 50)$ $= 0.13 \text{ N/mm}^2 \quad \text{low}$ <p><u>Serviceability Limit State</u> Global material safety factor = 1.8</p> $M_s = 0.62 \times 0.8 \times 1.24 \times 1.6^2 / 8 = \underline{0.2 \text{ kNm/m}}$ <p>Service bending stress = σ_s</p> $= 0.2 \times 10^6 / 1.0056 \times 10^5$ $= \underline{2 \text{ N/mm}^2}$ <p>LOP required @ 28 days = 1.8×2</p> $= \underline{3.6 \text{ N/mm}^2} < 6 \text{ N/mm}^2 \text{ OK}$ <p>Check integrity of ornate, central panel spanning vertically (shorter span)</p> <p><u>Ultimate Limit State</u></p> $\gamma_f = 1.4 \times 1.05 \times 1.05 \times 1 = 1.54$ <p>Consider width of 184mm (see illustration on Sh 1)</p> $M_u = 1.54 \times 0.62 \times 0.8 \times 0.184 \times 1.06^2 / 8$ $= \underline{0.02 \text{ kNm}}$ $Z = 42 \times 35^2 / 6 = 8575 \text{ mm}^3$ <p>Ultimate bending stress $\sigma_u = 0.02 \times 10^6 / 8575$</p> $= \underline{2.33 \text{ N/mm}^2} \text{ (tension)}$ $< 10/3 \text{ so OK}$ <p>Shear not critical</p> <p><u>Serviceability Limit State</u> Global material safety factor = 1.8</p> $M_s = 0.62 \times 0.8 \times 0.184 \times 1.06^2 / 8 = 0.013 \text{ kNm/m}$ <p>Service bending stress = σ_s</p> $= 0.013 \times 10^6 / 8575$ $= \underline{1.49 \text{ N/mm}^2}$ $< 6/1.8 \text{ so OK}$					<p>LOP @ 28 days = 6 N/sqr mm</p>

worked example - for demonstration purposes only

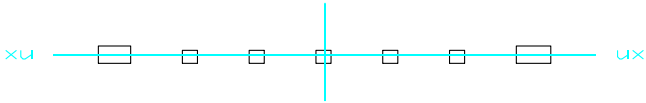
Title: Design Examples - Example No 10 - Sunscreen				Drg Ref		
Project No Ex10	By A R Glass	Checked AI Ways	Date Oct-03	Sheet No 3 of 3	Rev	
REF	CALCULATIONS					OUTPUT
						
	<p> Area = 1.6397E+04 (16396.7475) XBar = 6.2017E+02 (620.1661) YBar = 2.1604E+01 (21.6039) Ixx = 2.8556E+06 (2855648.4641) Iyy = 3.4769E+09 (3476883645.1719) Ixy = 9.2472E+03 (9247.2072) Iuu = 2.8556E+06 (2855648.4395) Ivv = 3.4769E+09 (3476883645.1965) Theta = 1.5251E-04 (0.0002) deg Zt = 1.0056E+05 (100564.8846) Zb = 1.3218E+05 (132181.9562) Zuu (Min) = 1.0056E+05 (100559.0379) Zvv (Min) = 5.6064E+06 (5606374.6884) rxx = 1.3197E+01 (13.1969) ryy = 4.6049E+02 (460.4858) ruu = 1.3197E+01 (13.1969) rvv = 4.6049E+02 (460.4858) </p>					

worked example - for demonstration purposes only

Design Examples - Example No 11 - Flex Anchor				Drg Ref		
Project No	By	Checked	Date	Sheet No	Rev	
Ex11	A R Glass	AI Ways	Oct-03	2 of 2		
REF	CALCULATIONS					OUTPUT
	<p>Check that flex anchor will not punch through facing</p> <p>Ultimate punching shear stress $v_c =$ $(1.46 \times 10^3) / (2 \times (8 + 110) \times 12)$ $= 0.32 \text{ N/mm}^2$ (Very conservative)</p> <p>Ultimate design stress for punching shear = $5/2.2$ $= 2.3 \text{ N/mm}^2$ $> 0.32 \text{ N/mm}^2$ OK</p> <p>This condition is not likely to be critical - unless the front GRC cover (12mm in this case) is compromised by poor manufacture.</p> <p>NOTE Clearly, the adequacy of the flex anchor itself should be checked for resisting 1.46 kN tension & compression without detrimental effects.</p> <p>Serviceability Limit State is deemed to have been satisfied.</p>					

worked example - for demonstration purposes only

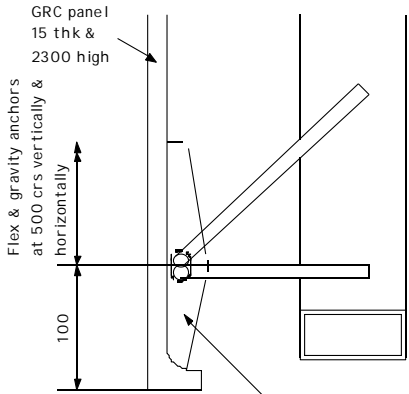
Title: Design Examples - Example No 12 - Gravity Anchor				Drg Ref																				
Project No Ex12	By A R Glass	Checked AI Ways	Date Oct-03	Sheet No 1 of 2	Rev																			
REF	CALCULATIONS					OUTPUT																		
	<div style="text-align: center;">  </div> <p style="text-align: center;">Grade (7/18) GRC Panel / Bonding Pad</p> <table style="width: 100%; border-collapse: collapse;"> <tr> <td style="width: 15%;">γ_f^*</td> <td style="width: 15%;">= 1.40</td> <td style="width: 70%;">Characteristic pull-off</td> </tr> <tr> <td>γ_{tv}</td> <td>= 1.10</td> <td>strength of bonding pad</td> </tr> <tr> <td>γ_b</td> <td>= 1.10</td> <td>= 3.5 kN (from tests)</td> </tr> <tr> <td>γ_c</td> <td>= 2.30</td> <td>Characteristic vert load</td> </tr> <tr> <td>γ_m</td> <td>= 2.20 (ULS)</td> <td>strength of bonding pad</td> </tr> <tr> <td></td> <td></td> <td>= 9.4 kN (from tests)</td> </tr> </table> <p>Wind loading = 2 kN/m²</p> <p>Ultimate Limit State</p> <p>$\gamma_f = 1.4 \times 1.1 \times 1.1 \times 2.3 = 3.90$</p> <p>(a) Negative Wind Pressure</p> <p>Gravity anchors are at 500mm crs in horiz direction</p> <p>Ultimate pull-off load/gravity anchor =</p> <p style="text-align: right;">$3.9 \times 2 \times 0.5 \times 0.35$ = 1.37 kN</p> <p>Design strength of bonding pad = $3.5/2.2 = 1.60$ kN > 1.37 kN OK</p> <p>(b) Positive Wind Pressure</p> <p>Not critical (see flex anchor example)</p> <p>(c) Vertical Loading (Self Wt)</p> <p>Ultimate vert load/gravity anchor =</p> <p style="text-align: right;">$3.9 \times 0.5 \times 2.3 \times 0.015 \times 20 \times 1.40$ = 1.88 kN</p> <p>(1.4 factor is 40% allowance for edge ribs and overspray)</p>					γ_f^*	= 1.40	Characteristic pull-off	γ_{tv}	= 1.10	strength of bonding pad	γ_b	= 1.10	= 3.5 kN (from tests)	γ_c	= 2.30	Characteristic vert load	γ_m	= 2.20 (ULS)	strength of bonding pad			= 9.4 kN (from tests)	
γ_f^*	= 1.40	Characteristic pull-off																						
γ_{tv}	= 1.10	strength of bonding pad																						
γ_b	= 1.10	= 3.5 kN (from tests)																						
γ_c	= 2.30	Characteristic vert load																						
γ_m	= 2.20 (ULS)	strength of bonding pad																						
		= 9.4 kN (from tests)																						

worked example - for demonstration purposes only

Design Examples - Example No 12 - Gravity Anchor				Drg Ref		
Project No Ex12	By A R Glass	Checked Al Ways	Date Oct-03	Sheet No 2 of 2	Rev	
REF	CALCULATIONS					OUTPUT
	<p>Design strength of bonding pad = $9.4/2.2 = 4.30$ kN > 1.88 kN OK</p> <p>Serviceability Limit State is deemed to have been satisfied.</p> <p>NOTE When combined effects of SW and lateral wind loading are large, it may be necessary to adopt a tee bar type of gravity anchor made out of welded flats.</p>					



The International Glassfibre Reinforced Concrete Association

www.grca.org.uk info@grca.org.uk +44 (0) 330 111 GRCA (4722)

PO Box 1454, NORTHAMPTON, NN2 1DZ. United Kingdom

A Company Limited By Guarantee, Registered in England: 01398450. VAT: GB 113 9195 20

Registered Office: Fairfax House, 6a Mill Field Road, Cottingley Business Park, Bradford BD16 1PY England