

**TATA STEEL**



# **Colorcoat® technical paper**

## Creating an air-tight building envelope



# Tata Steel and Part L

Over 50 years, Tata Steel has developed close strategic relationships with a number of market-leading roof and wall cladding system manufacturers.

Specifying Colorcoat® products through one of these strategic partners ensures access to the very best technical guidance and the highest levels of quality and service. Together we can provide a quality building envelope solution that delivers peace of mind.

## Working together to deliver Part L compliance

Tata Steel has worked closely with CA Group and Euroclad to prepare for the changes to Part L Building Regulations. This has involved developing a consistent approach, testing all systems for air-tightness and sharing best practice on thermal modelling of details.

Tata Steel, along with each of these strategic partners, prepared fully for the change to Part L regulations. Moreover, we have developed the data and details which will help architects demonstrate compliance with the new regulations.

# Contents

|   |    |
|---|----|
| Overview  | 3  |
| Significance of air-tightness on building energy performance            | 4  |
| Air-tightness testing facilities  | 8  |
| Achieving air-tightness using built-up systems                          | 10 |
| Achieving air-tightness using factory insulated composite panel systems | 14 |
| Applying the results in building design and construction                | 18 |
| Air-tightness in context  | 20 |
| Conclusion  | 21 |
| The Colorcoat® brand  | 22 |

## Overview

Environmental concerns and the rising cost of fuel mean that there is an increased focus on minimising energy use during the life of a building. The thermal performance of the building envelope plays a key role in this and tests show that achieving an air-tight envelope construction can more reliably create an energy efficient building than simply increasing levels of insulation. Metal-based cladding systems are inherently airtight and

therefore ideally suited to creating an airtight building envelope.

This Colorcoat® Technical Paper shows designers and constructors how a good level of air-tightness can be achieved using Colorcoat® pre-finished steel products from Tata Steel. It provides a short overview of the Part L Building Regulation requirements for air-tightness and practical guidance on the

common methods of jointing both built-up and factory insulated composite panel systems. The Colorcoat® Centre for the Building Envelope based at Oxford Brookes University has developed one of the world's most advanced testing facilities for assessing the air-tightness of building details. These facilities were used to test the air leakage rates using different joint configurations and the results are included in this paper.

# Significance of air-tightness on building energy performance

Changes to Part L and rising energy prices have put a renewed emphasis on improving the energy performance of buildings. Studies have shown that the simple approach of increasing insulation thickness is unlikely to pay off in the long run. Other means of reducing energy usage are now required.

Energy is lost through the building envelope via 3 main routes:

- Building fabric losses, through the insulation.
- Linear thermal bridging, through building details and areas of reduced thermal resistance.
- Air-tightness, the entry of cold air through joints and interfaces, which requires heating to the building's ambient temperature.

Figure 1. Factors which affect building CO<sub>2</sub> emission rate.

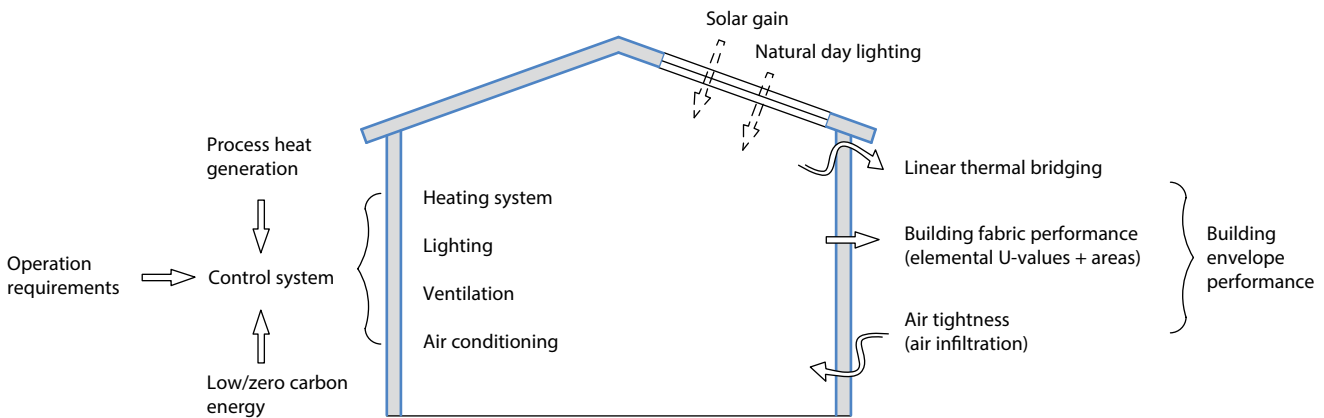

The evaluation of air infiltration rates for large buildings has established the following relationship:

$$\frac{\text{Air changes/hour} \times \text{envelope area}^*}{\text{Cladding area} \times 60} = \text{Air-tightness @ 50 Pa}$$

\* Envelope area is the cladding and floor slab area combined.

The energy (watts) required to heat the cold air entering the building is given by:

$$\frac{\text{Air changes/hour} \times \text{building volume} \times \text{specific heat capacity of air} \times \text{density of air} \times \text{temp raise}}{3600}$$

Figure 2. Building envelope energy losses for a 4000 m<sup>2</sup> 2013 Notional Building measuring 6 m to eaves.

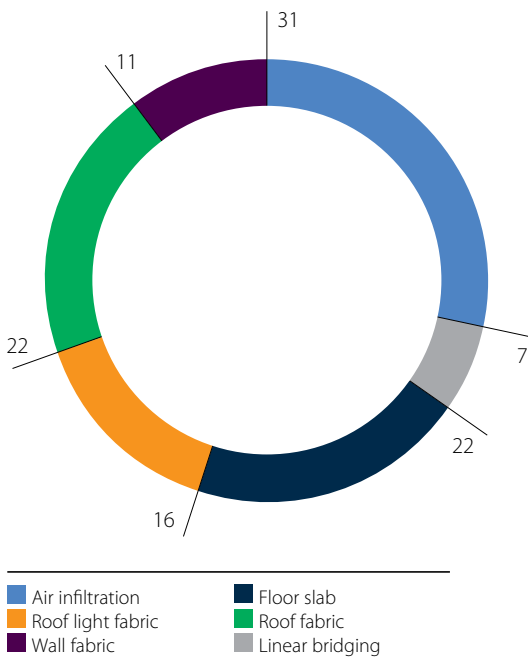

**Note:** values dependant on building geometry.

As illustrated, air-tightness offers the greatest opportunity for reducing heat loss through the building envelope. To maintain a good working environment within a building, a number of air changes per hour are necessary, dependent on activity levels. Best practice dictates that the building envelope should be as air-tight as possible, with controlled ventilation.

# Building regulation requirements. Approved document L (2013)

Air-tightness is measured in m<sup>3</sup> of air per hour per m<sup>2</sup> of building envelope at an applied pressure of 50 Pa. The area of the building envelope includes the walls, roof and floor slab. In practice, the floor slab can be considered air-tight.

The concept of air-tightness was first introduced into Building Regulations in England and Wales in the 2002 revision of "Approved Document L". In this document, a maximum allowable air leakage rate of 10 m<sup>3</sup>/h/m<sup>2</sup> was introduced for all buildings other than dwellings greater than 1000 m<sup>2</sup>.

The 2013 update to Part L has extended this further. All buildings must be pressure tested, unless the floor area is less than 500 m<sup>2</sup>, when a default value of 15 m<sup>3</sup>/h/m<sup>2</sup> can be used. For buildings over 500 m<sup>2</sup>, a maximum reasonable design limit for air-tightness is 10 m<sup>3</sup>/h/m<sup>2</sup>.

The 2013 revision of ADL 2A recognises that it is more difficult to achieve air-tightness on smaller buildings so has introduced a range of specifications for the Notional Building dependent upon the building size. See table 1.

It will be difficult to meet the overall building CO<sub>2</sub> emission rate without a reasonably air-tight building envelope.

Air-tightness is tested using a number of large mobile fan units, to pressurise the building to 50 Pa. The volume of air leakage is divided by the cladding (including floor slab) area.

**Table 1: Part L 2013 Notional building air-tightness for different size and type of buildings.**

| Gross internal floor area                    | Air tightness m <sup>3</sup> /m <sup>2</sup> /h |             |         |
|--|---|-------------|---------|
|  | Side Lit  | Side Lit    | Top Lit |
|  | Heat only                                       | Heat + Cool |         |
| < 250 m <sup>2</sup>                         | 5   | 5           | 7       |
| 250 m <sup>2</sup> – 3,500 m <sup>2</sup>    | 3   | 3           | 7       |
| 3,500 m <sup>2</sup> – 10,000 m <sup>2</sup> | 3   | 3           | 5       |
| 10,000 m <sup>2</sup> +                      | 3   | 3           | 3       |

## Potential air leakage paths

Pre-finished steel is inherently air-tight. The management of the interfaces between the cladding sheets is critical to ensure a high performance building envelope. The following interfaces should be considered:

- Metal cladding side and end lap joints.
- The interface between metal cladding and pre-fabricated flashings at building corners, ridges, eaves and verges.
- The interface between metal cladding and the floor slab/dwarf wall and other building envelope materials.
- Unplanned penetrations in the cladding.

This paper assesses the requirements for metal cladding side and end lap joints and the interface between metal cladding and flashing, although some of these principles can also be applied to other interfaces and penetrations.

### Achieving air-tightness

In a typical pre-finished steel-clad building, the air-tightness barrier is provided by the interior (or "liner") side of the envelope. While the outer sheet of an insulated envelope will provide weather protection, and will be sealed in order to prevent water leaks, it is important that it is not relied upon for air-tightness. This is for two main reasons:

1. The insulation cavity on a build up system is slightly ventilated to allow air movement and so eliminate potential condensation build up in the cavity.

2. Sealing at the liner side will prevent water vapour from inside the building penetrating the insulation.

The first step in constructing an air-tight building is to identify the liner as the air-tightness barrier and ensure this is focused on during the design and construction of the building envelope.

The means of achieving air-tightness for a building using a built-up, insulated, pre-finished steel cladding system will be

different from one clad with factory insulated composite panels. Both systems can provide extremely good air-tightness, using good detailing and construction.

## Built-up system

Air-tightness for built-up systems is generated by the liner sheet. Sealant tapes or beads are used to seal the overlap joints between adjacent sheets. It is normal practice to have a slightly vented insulation cavity to reduce condensation risks. The external or weather sheet of the building envelope does not normally contribute to air-tightness.

Figure 3. Cross section schematic through a built-up system.

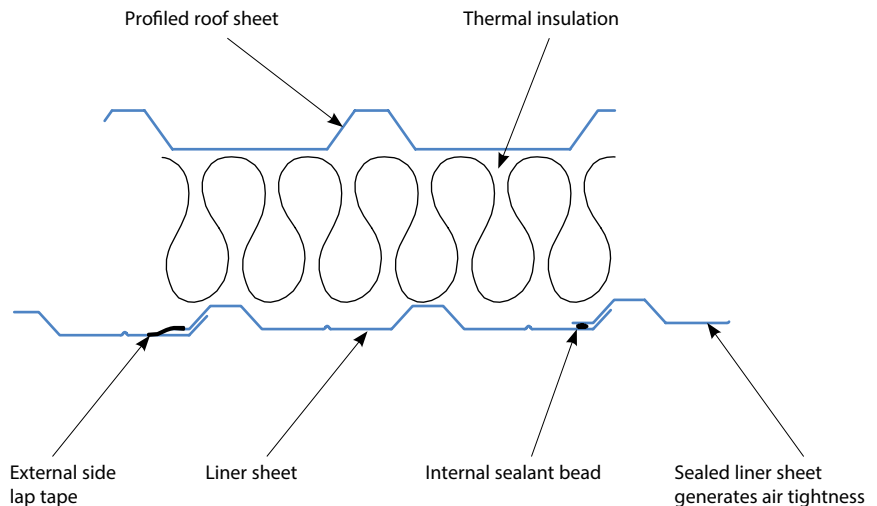

## Factory insulated composite panels

Air-tightness is achieved by the compression of factory fitted seals on the liner side of the joint. Sealant fitted on the outer sheet is for weather tightness only. Care must be taken to ensure that condensation does not occur inside the joint.

The position of the factory fitted seals will be specific to the individual panel. For further information on seal position and potential condensation contact the cladding system manufacturer.

Figure 4. Cross section schematic through a factory insulated composite panel system.

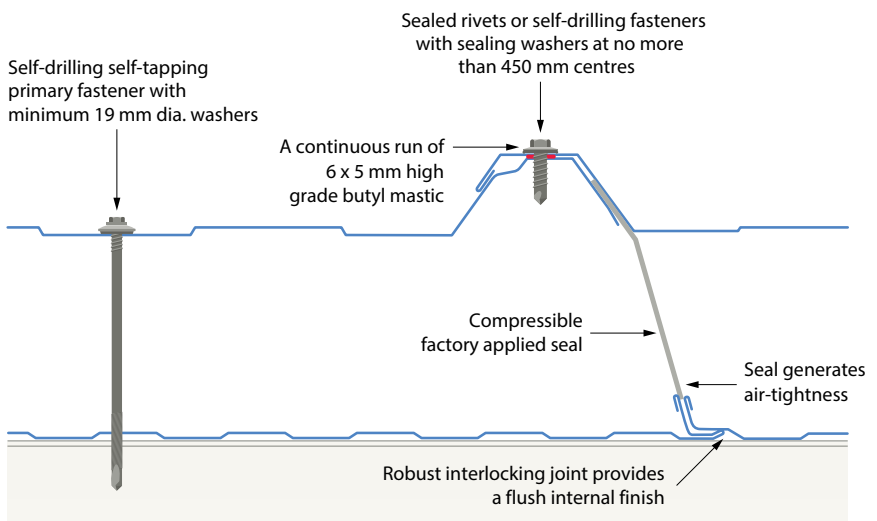

# Air-tightness testing facilities

Tata Steel has established the Colorcoat® Centre for the Building Envelope at Oxford Brookes University, to support research in the use of pre-finished steel in the building envelope. A key area of study is how the building envelope can contribute to the aims of sustainable development, with work focusing on minimising operational energy as well as life cycle analysis and the development of modern methods of construction.

This technology will be invaluable in helping architects and contractors comply with the changes to Part L (2013) Building Regulations. In developing these testing facilities with Oxford Brookes University Architectural School, Tata Steel believes the results will be used to provide more air-tight building details, reducing energy bills for the client and providing more security from uncertain fuel prices.

At the Colorcoat® Centre different cladding joint assemblies have been fabricated on a test

rig, which was then pressurised to 50 Pa (the same pressure used to test whole buildings). The pressure inside the test rig is automatically controlled, allowing the air leakage rate for the cladding system and per linear metre of joint to be calculated. The results of this study show that good air-tightness is achieved by what would be recognised as “best practice” rather than costly new systems.

A number of cladding joints have been assessed in order to provide this guidance:

## Built-up systems

- Side lap joints.
- End lap joints.
- Side lap to flashing joints.
- End lap to flashing joints.

## Factory insulated composite panel systems

- Side lap joints.
- End lap joints.
- Side lap to flashing joints.
- End lap to flashing joints.



Figure 5. Schematic of air-tightness test cell.

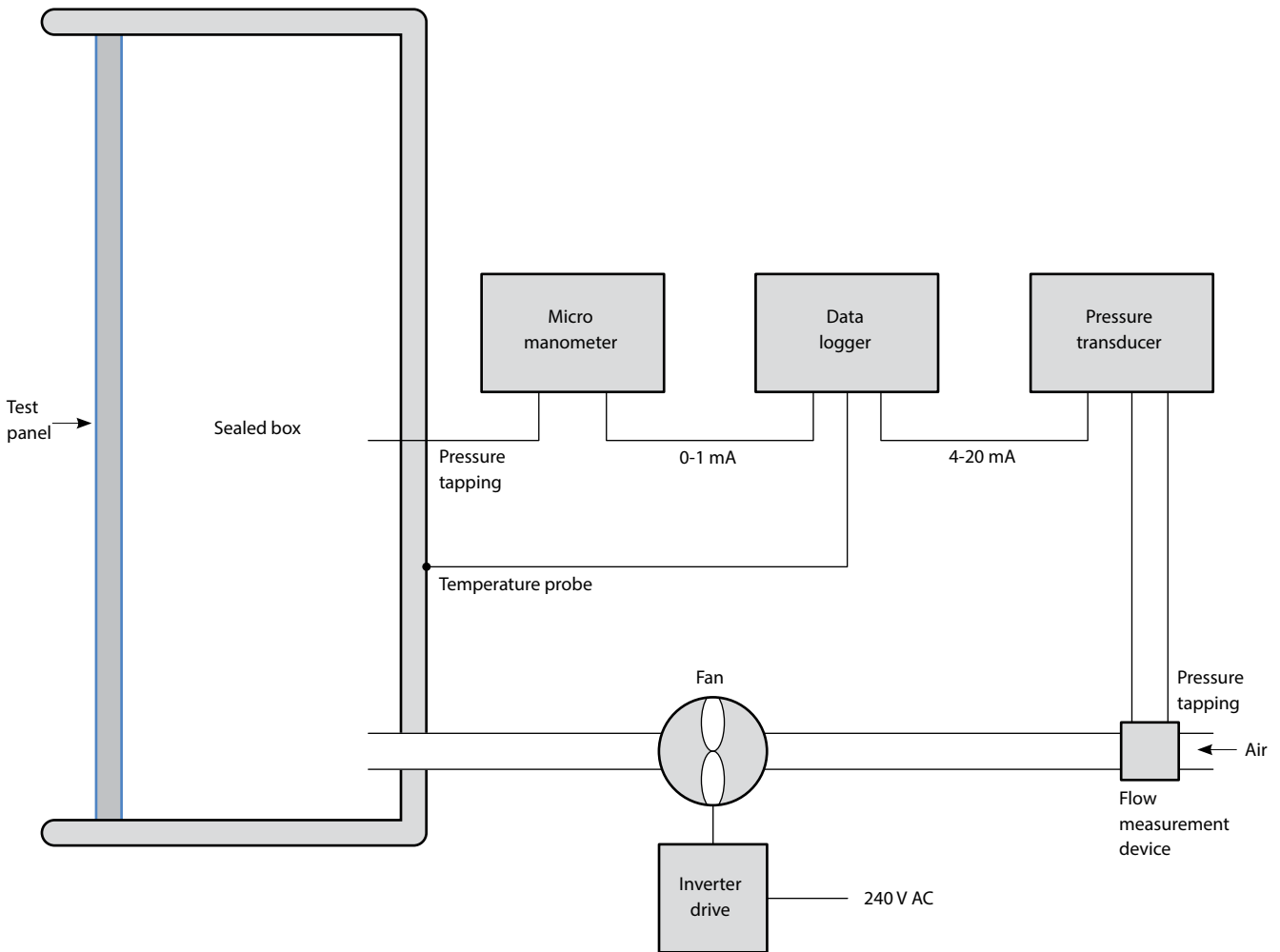

# Achieving air-tightness using built-up systems

## Built-up system side lap joints

Figure 6. Cross section schematic through a built-up system.

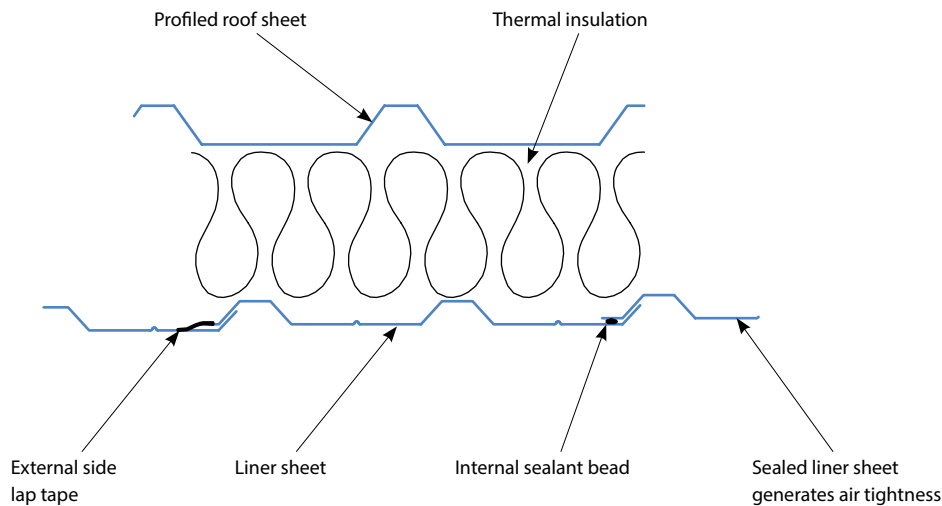

Side lap joints are formed where the profiled edge of one sheet overlaps the edge of the adjacent sheet. Liner sheets are normally 0.4 mm or 0.7 mm thick. The joint is sealed either using a sealant bead, which is placed inside the overlap joint, or an external tape, which is placed over the joint line on the cavity side of the liner sheet. The joint can be reinforced with stitcher screws or rivets. This is a requirement for most firewall constructions.

Side lap joints account for approximately 75% of joint length in the cladding. There is approximately 1 metre of joint for every square metre of cladding; depending on the sheet cover width. For this reason, effective sealing of this joint provides the basis of an air-tight cladding system.

Any edge damage to the sheet profile will affect the tightness of the overlap joint and the performance of unsealed joints will be poor and have a high degree of variability. The use of a good quality sealant tape (such

as Polyband or T-foil) or an internal sealant bead of the correct size will produce a good quality air-tight joint. When using an external tape, it is important to note that the stitcher screws will not provide any additional air-tightness, although they can add to the longevity of the joint. When using an internal

sealant bead, stitcher screws are necessary for compression of the bead, increasing the performance and longevity of the joint.

(Consult cladding system manufacturers for the recommended size and grade of sealant beads).

Table 2: Side lap joint configurations and corresponding air leakage rates

| Joint details                                | Leakage rate m <sup>3</sup> /m/h |              |
|--|----------------------------------|--------------|
|  | 0.4 mm liner                     | 0.7 mm liner |
| Unsealed unstitched                          | >10.00                           | >10.00       |
| Unsealed stitched @ 450 mm                   | >5.00                            | >5.00        |
| External sealant tape                        | <0.20                            | <0.20        |
| External sealant tape and stitching @ 450 mm | <0.20                            | <0.20        |
| Internal sealant bead                        | <0.25                            | <0.40        |
| Internal sealant bead and stitching @ 450 mm | <0.20                            | <0.20        |

### Key

■ Recommended specification

## Built-up system end lap joints

Figure 7. Schematic of a built-up system end lap joint.

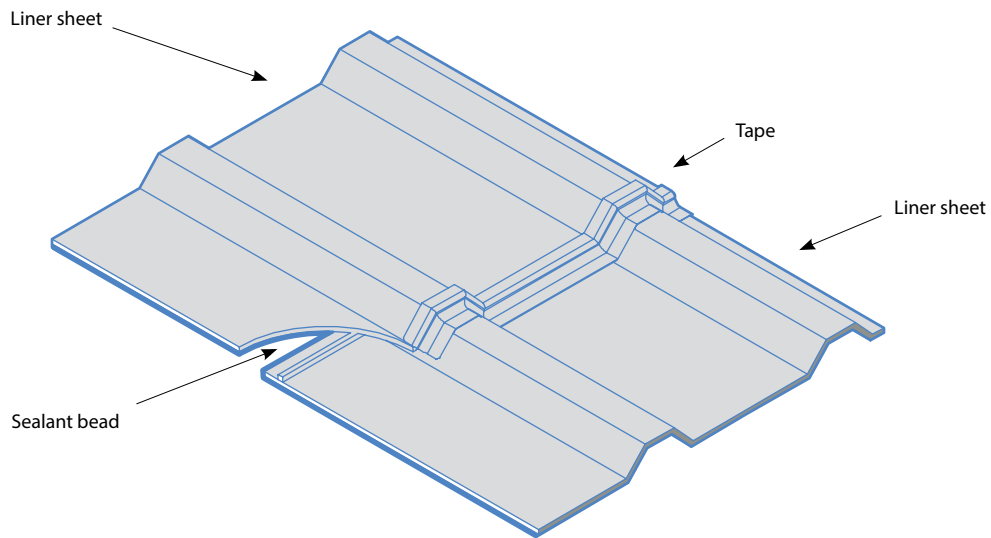

End lap joints are formed where the profiled end of one sheet overlaps the end of the adjacent sheet. The minimum recommended overlap is 60 mm. Liner sheets are normally 0.4 mm or 0.7 mm thick. The joint is sealed using a sealant bead, which is placed inside the overlap joint, or using an external tape, which is placed over the joint line on the cavity side of the liner sheet. The joint is reinforced with stitcher screws or rivets.

Stitcher screws should be fitted in every valley to provide compression of the sealant bead. The use of a good quality sealant bead of the correct size will produce a good quality air-tight joint. If the sheet is secured only in alternate valleys, the unsecured valleys can open slightly, stressing the sealant bead and compromising the performance and longevity of the joint.

An external sealant tape can provide an air-tight joint, but is difficult to secure accurately around the profiles, which can lead to workmanship issues and reduced performance. Poorly laid

tape can also trap internal condensation, resulting in potential corrosion of the liner sheet.

(Consult cladding system manufacturer for the recommended size and grade of sealant beads / tapes).

Table 3: End lap joint configurations and corresponding air leakage rates

| Joint details                                     | Leakage rate m <sup>3</sup> /m/h |              |
|---|----------------------------------|--------------|
|   | 0.4 mm liner                     | 0.7 mm liner |
| Unsealed, stitched alternate valleys              | <45.00                           | <45.00       |
| Unsealed, stitched every valley                   | <15.00                           | <15.00       |
| Internal sealant bead, stitched alternate valleys | <1.00                            | <0.50        |
| Internal sealant bead stitched every valley       | <0.30                            | <0.30        |
| External sealant tape, stitched alternate valleys | <0.20                            | <0.20        |
| External sealant tape, stitched every valley      | <0.20                            | <0.20        |

### Key

■ Recommended specification

## Built-up system side lap to flashing joint

Figure 8. Cross section schematic of a built-up system side lap to flashing joint.

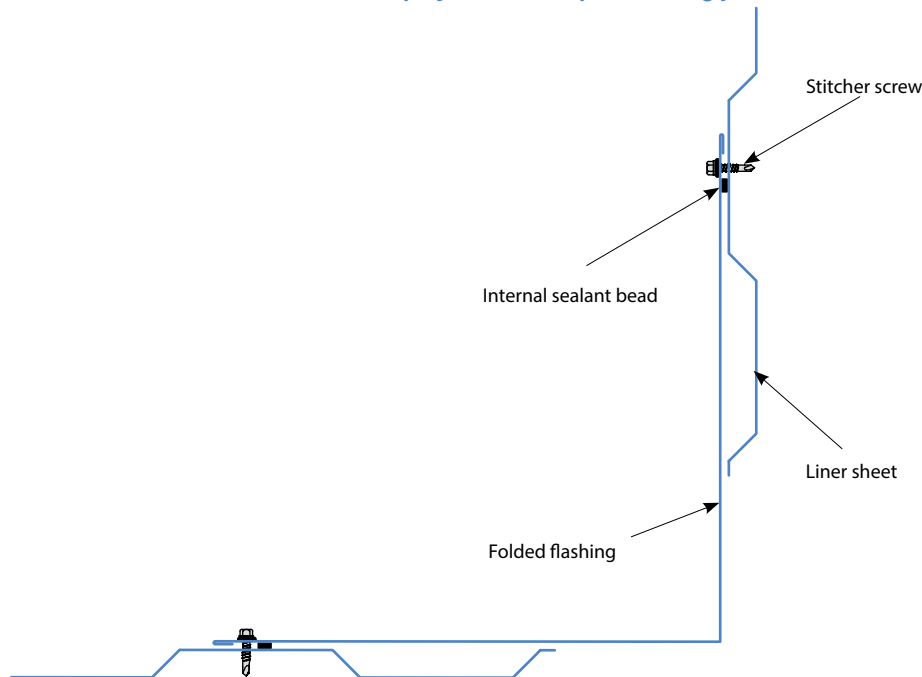

This joint is formed where the edge of the folded flashing sheet overlaps the edge of the adjacent sheet as in a vertical corner. Liner sheets are normally 0.4 mm or 0.7 mm thick, flashings are normally 0.7 mm thick. The overlap joint is sealed using a sealant bead, which is placed inside the overlap. The joint is reinforced with stitcher screws or rivets.

The performance of this joint is very similar to a normal side lap joint. The use of stitcher screws is essential to ensure adequate compression of the internal sealant bead. An external sealant tape can also be used with some liner sheet profiles. This should be placed on the cavity side.

(Consult cladding system manufacturers for the recommended size and grade of sealant beads).

Table 4: Side lap/flashing joint configurations and corresponding air leakage rates

| Joint details                            | Leakage rate m <sup>3</sup> /m/h |              |
|--|----------------------------------|--------------|
|  | 0.4 mm liner                     | 0.7 mm liner |
| Internal sealant bead, stitched @ 900 mm | >0.25                            | >0.25        |
| Internal sealant bead, stitched @ 450 mm | >0.20                            | >0.20        |

### Key

■ Recommended specification

## Built-up system end lap to flashing joints

Figure 9. Schematic of a built-up system end lap to flashing joint.

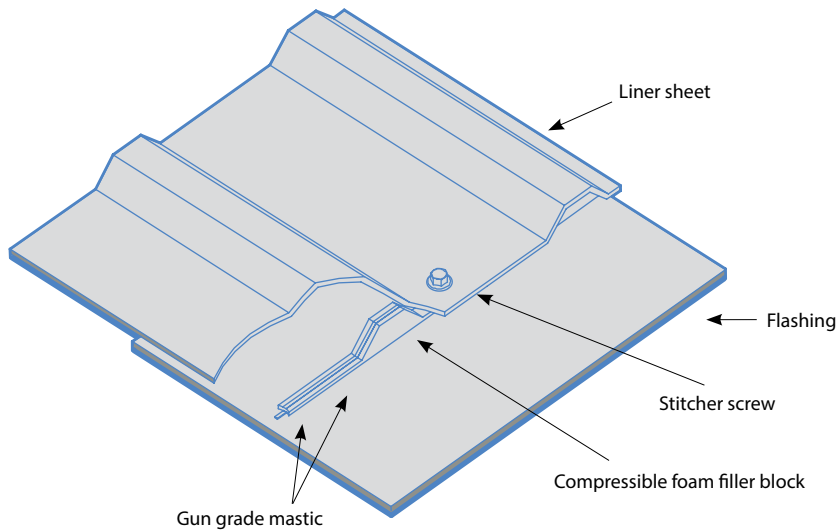

This joint is formed where the end of the profiled sheet overlaps the folded flashing sheet as in a ridge or eaves detail.

The minimum recommended overlap is 75 mm. Liner sheets are normally 0.4 mm or 0.7 mm thick, whilst flashings are normally 0.7 mm thick. The joint is sealed using profiled filler blocks, which fit into the liner sheet profile and become compressed between the profile and the flashing. Filler blocks are generally made from Ethylene Propylene Diene Monomer (EPDM) or Polyethylene (PE) foam. Stitcher screws create compression and reinforcement of the joint.

It is essential that filler blocks are matched to the profile of the cladding sheet used. The use of a suitable gun-grade mastic to bond the filler blocks in position will generally increase performance and also assists with locating the blocks during assembly.

To ensure good compression of the filler blocks and longevity of the joint, the sheeting should be secured through every valley.

There is no discernable difference in performance between EPDM and PE filler blocks.

Table 5: End lap/flashing joint configurations and corresponding air leakage rates

| Joint details                                       | Leakage rate m <sup>3</sup> /m/h |              |
|---|----------------------------------|--------------|
|   | 0.4 mm liner                     | 0.7 mm liner |
| EPDM filler block stitched alternate valleys        | <10.00                           | <5.00        |
| PE filler block stitched alternate valleys          | <10.00                           | <5.00        |
| Bonded EPDM filler block stitched alternate valleys | <2.00                            | <2.00        |
| Bonded PE filler block stitched alternate valleys   | <2.00                            | <2.00        |
| EPDM filler block stitched every valleys            | <0.50                            | <0.50        |
| PE filler block stitched every valleys              | <0.50                            | <0.50        |
| Bonded EPDM filler block stitched every valleys     | <0.25                            | <0.25        |
| Bonded PE filler block stitched every valley        | <0.25                            | <0.25        |

### Key

■ Recommended specification

# Achieving air-tightness using factory insulated composite panel systems

## Factory insulated composite panel system side lap joints

Figure 10. Cross section schematic through a factory insulated composite panel system.

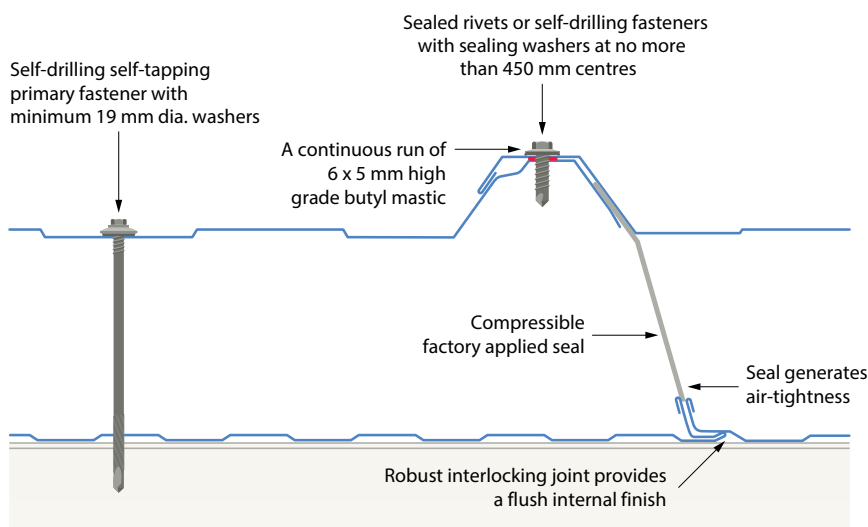

The edge detail of a factory insulated composite panel is designed to interlock with its adjacent panel, forming an air-tight and weather-tight seal. A compressible foam seal is usually incorporated into the edge tape detail, which seals against the adjacent panel. The two panels must be held tightly together during installation to ensure adequate compression of the seal. Additional supplementary sealing may also be used.

Side lap joints typically account for approximately 75% of joint length in the cladding. There is approximately 1 metre of joint

for every square metre of cladding, depending on the panel cover width. For this reason, effective sealing of these joints provide the basis of an air-tight cladding system.

Performance of the basic joint is reliant on adequate compression of the internal tape seal. Any edge damage to the panel or panel misalignment, could mean that joints do not fully close, therefore compromising air-tightness. The use of an additional sealant bead, or foam seal, in addition to the internal edge tape seal will greatly enhance performance and tolerance of the joint to inadequate lateral compression.

It should be noted that this in effect moves the air-tight barrier to the outer sheet and could potentially cause a build up of condensation in the joint detail.

The use of a supplementary foam seal (or mastic bead) in the interlocking joint on the liner side of the panel will greatly enhance performance and tolerance of the joint to inadequate lateral compression. Importantly, this also maintains the air seal on the liner side of the panel. (Consult cladding system manufacturers for recommended size and grade of sealant/foam seals.)

Table 6: Side lap joint configurations and corresponding air leakage rates for varying lateral compression

| Joint details               | Leakage rate m <sup>3</sup> /m/h |                                     |                                       |
|-----------------------------|----------------------------------|-------------------------------------|---------------------------------------|
|                             | Foam edge seal only              | Foam edge and external sealant bead | Foam edge seal and external foam seal |
| Fully compressed joint      | <0.50                            | <0.20                               | <0.20                                 |
| Joint compressed to 1.75 mm | <0.50                            | <0.20                               | <0.20                                 |
| Joint compressed to 3.5 mm  | >10.00                           | <0.20                               | <0.20                                 |

\* The performance of the joint is dependant on the size of the internal foam seal fitted. A larger seal will be more tolerant of inadequate joint compression.

# Factory insulated composite panel system end lap joints

Figure 11. Cross section schematic of a factory insulated composite panel system end lap joint.

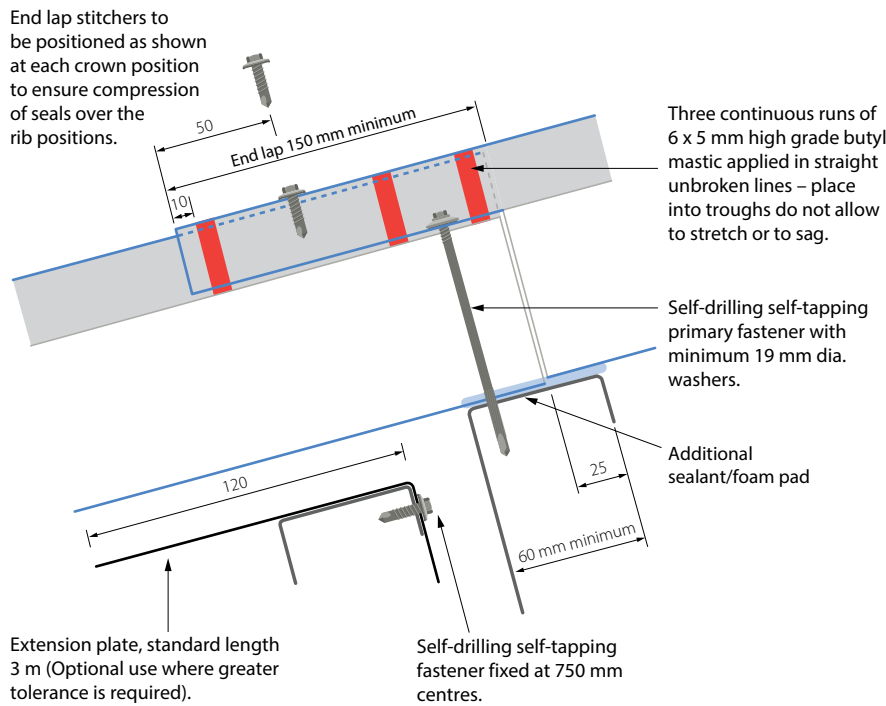

This joint is formed where the profiled end of an external sheet overlaps the end of the adjacent sheet. The joint must be sited over a purlin/sheeting rail. The liner and insulation foam on the overlapping panel must be cut back to facilitate this, a process which is usually done during panel manufacture. The minimum recommended overlap is 150 mm. The joint is sealed using a sealant bead, which is placed inside the overlap joint. A compressible foam tape or mastic bead,

can also be applied to the purlin. The joint is reinforced with stitcher screws or rivets, which also compress the sealant beads.

The use of sealant beads in the external sheet overlap joint will, when adequately secured, result in an air-tight joint. Alternate through fixings will provide adequate compression of the sealant beads. It should be noted, however, that this is effectively moving the air-tight barrier

to the outer sheet, which could potentially cause a build up of condensation in the joint detail. The use of supplementary foam seals (or mastic beads) on the purlin will provide an effective seal on the liner side of the panel and will greatly enhance performance.

(Consult cladding system manufacturers for recommended size and grade of sealant/foam seals.)

Table 7: End lap joint configurations and corresponding air leakage rates

| Joint details   | Leakage rate m <sup>3</sup> /m/h |
|---|----------------------------------|
| No sealant, alternate valley through fix only                                   | <2.50                            |
| No sealant, alternate valley through fix. Alternate valley stitched             | <2.50                            |
| 3 sealant beads, alternate valley through fix only                              | <0.30                            |
| 3 sealant beads, alternate valley through fix. Alternate valley stitched        | <0.30                            |
| 3 sealant beads, alternate valley through fix. Foam pad/sealant beads on purlin | <0.20                            |

**Key**

■ Recommended specification

# Factory insulated composite panel system side lap to flashing joints

Figure 12. Cross section schematic of a factory insulated composite panel system side lap to flashing joint.

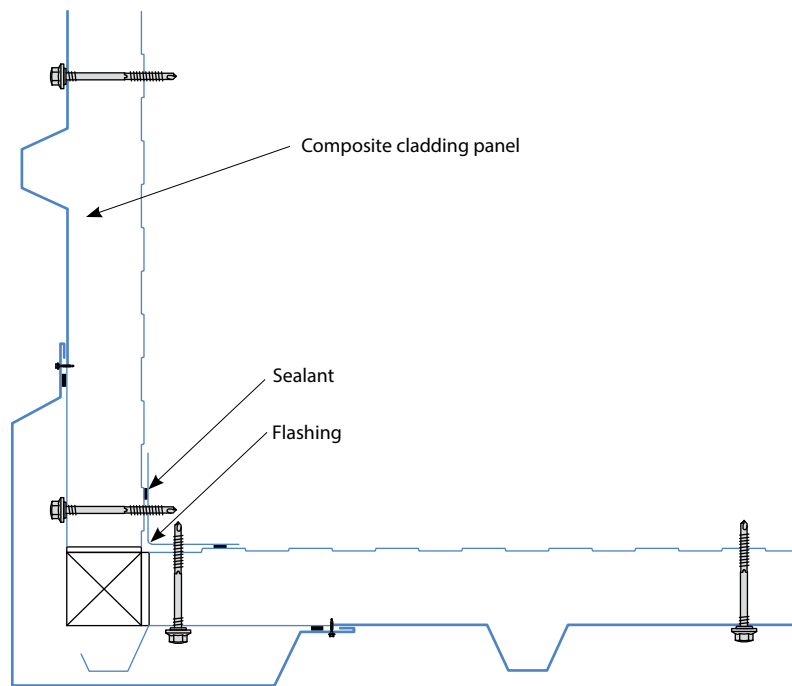

This joint is formed where the panel edge overlaps the edge of the folded flashing sheet as in a vertical corner. Flashings are normally 0.7 mm thick. The overlap joint is sealed using a sealant bead, which is placed inside the overlap joint. The joint is reinforced with stitcher screws or rivets, which also compress the sealant bead.

The performance of this joint is very similar to a built-up system, flashing joint. The use of stitcher screws is essential to ensure adequate compression of the internal sealant bead.

(Consult cladding system manufacturers for recommended size and grade of sealant/foam seals.)

Table 8: Side lap/flashing joint configurations and corresponding air leakage rates

| Joint details                             | Leakage rate m <sup>3</sup> /m/h |
|---|----------------------------------|
| Internal sealant bead, stitched @ 1900 mm | <1.50                            |
| Internal sealant bead, stitched @ 900 mm  | <0.25                            |
| Internal sealant bead, stitched @ 450 mm  | <0.20                            |

**Key**

■ Recommended specification



# Factory insulated composite panel system end lap to flashing joints

Figure 13. Schematic of a factory insulated composite panel system end lap to flashing joint.

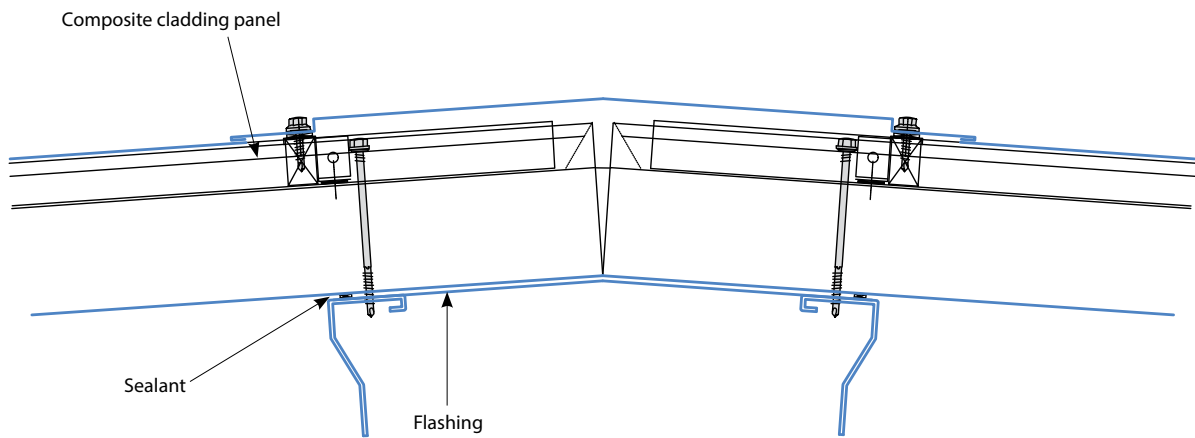

This joint is formed where the end of the panel overlaps the edge of the folded flashing sheet as in a ridge or eaves detail. Flashings are normally 0.7 mm thick. The overlap joint is sealed using a sealant bead which is placed inside the overlap joint. The minimum recommended overlap is 75 mm.

It should be noted that profiled filler blocks are not normally used, due to the very shallow

micro rib/plank profile of the internal liner sheet. Compression of the sealant and reinforcement of the joint is created by sticher screws/primary fasteners.

Due to the rigidity of the panel, there is minimal difference in performance when additional fasteners are used. Through fixings should be specified for every valley for structural (wind load) requirements.

The sealant bead must be of an adequate size to accommodate the small profile in the liner sheet of the composite panel.

(Consult cladding system manufacturers for recommended size and grade of sealant/foam seals.)

Table 9: End lap/flashing joint configurations and corresponding air leakage rates

| Joint details                                  | Leakage rate m <sup>3</sup> /m/h |
|--|----------------------------------|
| No sealant. Alternate through fix              | >20.00                           |
| Internal sealant bead. Alternate through fix   | <0.20                            |
| Internal sealant bead through fix every valley | <0.20                            |

### Key

■ Recommended specification

# Applying the results in building design and construction

The tables below summarise recommended practices and measured joint leakage rates. The building envelope is configured using combinations of the joints included here, for example, a gable joint incorporates flashing to side lap and flashing to end lap joints.

The tables below summarise recommended practices and measured joint leakage rates. The building envelope is configured using combinations of the joints included here, for example, a gable joint incorporates flashing to side lap and flashing to end lap joints.

**Table 10: Built-up system – recommended joint sealing practice**

| Joint details           | Recommendation  | Leakage rate m <sup>3</sup> /m/h |
|-------------------------|---|----------------------------------|
| Side lap joint          | External sealant tape                                 | <0.20                            |
|                         | Internal sealant bead, stitched @ 450 mm              | <0.20                            |
| Side lap flashing joint | Internal sealant bead, stitched @ 450 mm              | <0.20                            |
|                         | External sealant tape                                 | <0.20                            |
| End lap joint           | Internal sealant bead, stitched every valley          | <0.30                            |
| End lap flashing joint  | Bonded EPDM or PE filler block, stitched every valley | <0.25                            |

**Table 11: Factory insulated composite panels – recommended joint sealing practice**

| Joint details           | Recommendation  | Leakage rate m <sup>3</sup> /m/h |
|-------------------------|---|----------------------------------|
| Side lap joint          | Fully compressed edge seal  | <0.50                            |
|                         | Additional internal foam seal on liner sheet interlock                          | <0.20                            |
| Side lap flashing joint | Internal sealant bead, stitched @ 450 mm  | <0.20                            |
| End lap joint           | 3 sealant beads, alternate valley through fix. Foam pad/sealant beads on purlin | <0.10                            |
| End lap flashing joint  | Internal sealant bead, through fix every valley                                 | <0.20                            |

A pre-finished steel building envelope can easily surpass the requirements of the revised Part L (2013) provided that the metal cladding joints are correctly installed in accordance with the system manufacturers guidance and that an approved sealant tape or internal sealant bead is used. Consult with cladding system manufacturers for the recommended size and grade of sealant bead.

It is important to recognise that construction site conditions are not always ideal. The Colorcoat® Centre for the Building Envelope

carried out tests to assess whether real world issues, such as damp or dirty pre-finished steel surfaces, will affect the bond of the sealant tape to the liner sheet. These indicate that provided the material is only moderately wet/dirty, (typical of early morning dew and airborne construction dust) and that adequate pressure is applied when fitting the sealant tape, a good quality seal can still be achieved. Care must be taken to ensure that damage does not occur to sheet edges and that debris is not present in overlap joints.

**Table 12: Built-up systems. Side lap joint leakage rates under simulated site conditions**

| Joint details             | Leakage rate m <sup>3</sup> /m/h |        |        |                   |
|---------------------------|----------------------------------|--------|--------|-------------------|
|                           | Standard joint                   | Damp   | Dirty  | Reduced pressure* |
| Unsealed unstitched       | >10.00                           | >10.00 | >10.00 | N/A               |
| Unsealed stitched @ 450mm | >5.00                            | >5.00  | >5.00  | N/A               |
| External sealant tape     | <0.20                            | <0.20  | <0.50  | <0.50             |

\* Reduced pressure was simulated by applying the tape using a hand brush.

Provided pre-finished steel cladding is correctly installed, the main sources of air infiltration will be other elements of the building envelope, such as: interfaces with other cladding materials, for example masonry dwarf walls or the floor slab, unplanned penetrations through the building envelope and gaps around vehicle access doors. Further work is currently underway at the Colorcoat® Centre for the building envelope and better understanding of these complex joints.

Use of the principles detailed in the Colorcoat® Technical Paper will minimise air leakage around such elements but it is important at the design stage to consider minimising difficult functions or leaky materials such as blockwork or masonry.

Attention to detail and a high standard of site workmanship are required to ensure that unplanned leakage paths are minimised. Testing has been carried out to establish the

leakage rate through unplanned holes in the metal cladding.

Building practice has focused on sealing the outer sheet of a built-up system to ensure a weather tight envelope. Similar attention to detail should also be paid to the seal on the liner side of the envelope to ensure continuity of the air-tight layer.

**Figure 14. Air-leakage rate for holes.**

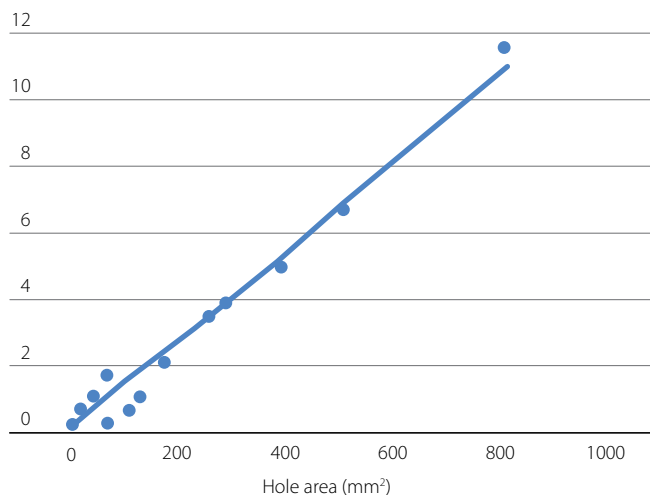

**Key**

■ Air leakage rate (m<sup>3</sup>/h)

# Air-tightness in context

This illustrates how a building would achieve an air-tightness rating which complies with Part L Regulations. For the dimensions specified below this building would be allowed a maximum air permeability at 50 Pa of  $10 \times 3729 = 37290 \text{ m}^3/\text{h}$ .

**Table 13: Details of joint lengths and associated average joint leakage rates**

| Building dimensions   |     |   |        |
|-----------------------|-----|---|--------|
| Height (m)            | 8   | Number of ridges                                | 1      |
| Width (m)             | 20  | Roof pitch height (m)                           | 1.1    |
| Length (m)            | 60  | Roof slope length (m)                           | 10.1   |
| Wall panel width (m)  | 1   | Floor area (m <sup>2</sup> )                    | 1200.0 |
| Wall panel height (m) | 4   | Roof area (m <sup>2</sup> )                     | 1206.6 |
| Roof panel width (m)  | 1   | Wall area (m <sup>2</sup> )                     | 1322.0 |
| Roof panel height (m) | 3.3 | Envelope area including floor (m <sup>2</sup> ) | 3728.7 |
| Roof pitch (degrees)  | 6   | Total enclosed volume (m <sup>3</sup> )         | 9610.5 |

| Joint details        | Leakage from joints – linear leakage of (m <sup>3</sup> /m/h) |            |            |             |             |             |             |
|----------------------|---|------------|------------|-------------|-------------|-------------|-------------|
|                      | Length (m)  | 0.10       | 0.25       | 0.50        | 1.00        | 2.00        | 3.00        |
| CornerRadius         | 32.0  | 3.20       | 8.00       | 16.00       | 32.00       | 64.00       | 96.00       |
| Wall side lap        | 1266.9  | 126.69     | 316.73     | 633.46      | 1266.92     | 2533.84     | 3800.76     |
| Wall end lap         | 160.0   | 16.00      | 40.00      | 80.00       | 160.00      | 320.00      | 480.00      |
| Roof side lap        | 1186.5  | 118.65     | 296.62     | 593.25      | 1186.50     | 2373.00     | 3559.50     |
| Roof end lap         | 240.0   | 24.00      | 60.00      | 120.00      | 240.00      | 480.00      | 720.00      |
| Verge                | 40.2  | 4.02       | 10.06      | 20.11       | 40.22       | 80.44       | 120.66      |
| Eaves                | 120.0   | 12.00      | 30.00      | 60.00       | 120.00      | 240.00      | 360.00      |
| Perimeter            | 160.0   | 16.00      | 40.00      | 80.00       | 160.00      | 320.00      | 480.00      |
| Ridge                | 60.0  | 6.00       | 15.00      | 30.00       | 60.00       | 120.00      | 180.00      |
| Valley               | 0.0   | 0.00       | 0.00       | 0.00        | 0.00        | 0.00        | 0.00        |
| <b>Total leakage</b> |   | <b>327</b> | <b>816</b> | <b>1633</b> | <b>3266</b> | <b>6531</b> | <b>9797</b> |

If all the relevant joints had a linear leakage of  $0.5 \text{ m}^3/\text{m/h}$ , the total leakage from the pre-finished steel envelope attributable to joints would be  $0.43 \text{ m}^3/\text{m/h}$  or 4.3% of the maximum allowable leakage.

It can be seen from this example that correct sealing of the metal to metal end and side lap joints, which form the majority of the potential air leakage paths, forms the basics of a good air tightness performance.

# Conclusions

In summary, it is worth remembering that steel is an inherently air-tight material, so the only air-leakage paths in a steel building envelope are where there are gaps left at junctions. Adopting the approaches detailed in this paper should minimise gaps at the majority of junctions. It should be noted, however, that a target air-leakage rate of 10, 5 or even 3 m<sup>3</sup>/m<sup>2</sup>/h allows, on average, a gap of 700 mm<sup>2</sup>, 380 mm<sup>2</sup> or 200 mm<sup>2</sup> for every 1 m<sup>2</sup>. Given that the target air-tightness is for the whole building (including all openings, interfaces, floors, roof and walls) it is essential that the techniques described here are

adopted for the areas which are relatively easy to control, since gaps will inevitably appear elsewhere in the construction.

Experience has shown that with close attention to detail, steel-clad buildings should have no difficulty in achieving air-leakage rates of no more than 5 m<sup>3</sup>/m<sup>2</sup>/h, and often even less than 3 m<sup>3</sup>/m<sup>2</sup>/h. However, air-leakage is highly dependent on building geometry. Simple, large buildings have proportionately less potentially-leaky interfaces than more complex, small ones.

## CPD accreditation

This paper has been assessed and approved as conforming to RIBA CPD guidelines. As such the content has been designated to fit under the following core curriculum headings:

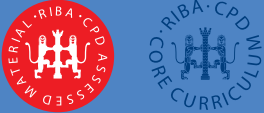

### General Headings

1. Professional context
2. Construction skills

### Subjects

1. Sustainable design
2. Specification writing and choosing materials

### Knowledge level

### General awareness

To receive a CPD certificate for this paper, please go to [www.colorcoat-online.com/cpd](http://www.colorcoat-online.com/cpd) where you will be asked to correctly answer five short questions on the content of the paper before being issued with an electronic certificate.





## The Colorcoat® brand

The Colorcoat® brand provides the recognised mark of quality and metal envelope expertise exclusively from Tata Steel. For 50 years Tata Steel has developed a range of technically leading Colorcoat® pre-finished steel products which have been comprehensively tested and are manufactured to the highest quality standards. These are supported by a range of services such as comprehensive guarantees, colour consistency and technical support and guidance.

Colorcoat® products are manufactured in the UK and are certified to independently verified international management system, ISO 14001 and are fully recyclable, unlike most other construction products.

## Colorcoat® products and services

Colorcoat® products offer the ultimate in durability and guaranteed performance reducing building life cycle costs and environmental impact.

We have detailed Life Cycle Costing and Life Cycle Assessment information that demonstrates the positive performance of Colorcoat® products when compared with other alternatives. This is available from [www.colorcoat-online.com](http://www.colorcoat-online.com)

### Colorcoat® BES 6001 approved

Colorcoat® pre-finished steel products manufactured in the UK are certified to BES 6001 Responsible Sourcing standard, the first steel envelope products in the world to achieve this.

### Colorcoat HPS200 Ultra®

Colorcoat HPS200 Ultra® pre-finished steel combines outstanding performance with exceptional durability and comes with the Confidex® Guarantee for up to 40 years for the weatherside of industrial and commercial buildings with no inspection or maintenance to maintain its validity.

### Colorcoat Prisma®

Designed to withstand the rigours of the external environment, versatile, lightweight and strong, Colorcoat Prisma® pre-finished steel is the ideal choice for your building envelope for contemporary, long lasting colour.

Whatever your type of building from warehouses to offices, or schools to houses, Colorcoat Prisma® offers you a range of attributes that enables you to create beautiful, modern and durable roofs and walls, Confidex® guaranteed for up to 30 years.

### Confidex® Guarantee

Offers the most comprehensive guarantee for pre-finished steel products in Europe and provides peace of mind for up to 40 years upon registration. Unlike other guarantees, Confidex® covers cut edges for the entirety of the guarantee period with no inspection or maintenance to maintain its validity. Available only with Colorcoat HPS200 Ultra® and Colorcoat Prisma®.

The Confidex® Guarantee includes cover for Colorcoat HPS200 Ultra® under photovoltaic (PV) modules for the full guarantee period. PV modules can be installed at any time during the Confidex® Guaranteed Period and the pre-finished steel will be covered for the remainder of the guarantee period.

For further information on Colorcoat® products and services please contact the Colorcoat Connection® helpline on +44 (0)1244 892434 or email [colorcoat.connection@tatasteel.com](mailto:colorcoat.connection@tatasteel.com) Alternatively visit [www.colorcoat-online.com](http://www.colorcoat-online.com)



# Colorcoat® Technical Support Team

Colorcoat® products are supported by a comprehensive range of services, technical advice and guidance. Our knowledge and expertise of the complete range of building envelope systems available with Colorcoat® products, means that the advice and support that we can offer you is truly objective.

We can help you to achieve the best technical solution for your building with the optimum in performance and environmental credentials. If you are building to specific sustainability credentials or performance criteria, we can work with you at the design phase of your project to help you integrate these requirements and deliver technically superior buildings that match your vision.

Whether you require information on the latest building regulations, calculations for a specific project or advice on integrating renewable technologies you can contact the Colorcoat Connection® helpline on +44 (0) 1244 892434 to request a visit from your regional representative for impartial

advice and support on a broad range of topics including:

- Specification support.
- CDM Regulations.
- Building Regulations.
- Energy Efficiency, savings and paybacks.
- Building integrated renewable technologies.
- Responsible sourcing to BES 6001.
- System suitability, durability and guarantees for project specific applications.
- Environmental Product Declarations.
- Structural implications.
- Health and Safety.
- Fire performance.
- Acoustics.
- Sustainability assessment tools such as BREEAM.

## Colorcoat Connection® helpline

This dedicated helpline offers immediate and easily accessible advice and guidance on a wide range of construction industry issues. Contact us on +44 (0) 1244 892434 or email [colorcoat.connection@tatasteel.com](mailto:colorcoat.connection@tatasteel.com)

# www.colorcoat-online.com

## **Trademarks of Tata Steel UK Limited**

Colorcoat, Colorcoat Connection, Colorcoat HPS200 Ultra, Confidex, Confidex Sustain, Prisma and Repertoire are trademarks of Tata Steel.

Care has been taken to ensure that the contents of this publication are accurate, but Tata Steel Europe Limited and its subsidiaries, (including Tata Steel UK Limited), do not accept responsibility or liability for errors or information that is found to be misleading. Suggestions for, or descriptions of, the end use or application of products or methods of working are for information only and Tata Steel Europe Limited and its subsidiaries accept no liability in respect thereof.

Before using products or services supplied or manufactured by Tata Steel Europe Limited and its subsidiaries, customers should satisfy themselves as to their suitability.

Printed with biodegradable vegetable inks on material sourced from responsible managed forests, certified in accordance with the FSC. Contains 10% recovered fibre, diverting waste from landfill.

## **Tata Steel**

Shotton Works

Deeside

Flintshire

CH5 2NH

T: +44 (0) 1244 812345

F: +44 (0) 1244 892345

[www.colorcoat-online.com](http://www.colorcoat-online.com)

## **Colorcoat Connection® helpline**

T: +44 (0)1244 892434

F: +44 (0)1244 892321

e-mail: [colorcoat.connection@tatasteel.com](mailto:colorcoat.connection@tatasteel.com)

Tata Steel UK Limited, Registered Office: 30 Millbank London SW1P 4WY, Registered in England No. 2280000

Copyright 2016

Language English PDF:ENG:0916